



# Friia Lite

## Service Manual



- 1000201\* - FRIIA LITE Chiller**  
• **1000202\* -FRIIA LITE Chiller/Carbonator**

[www.marco beveragesystems.com](http://www.marco beveragesystems.com)

Ireland Tel: +353 (1) 295 2674

UK Tel: +44 (0207) 2744577

<b>1</b>	<b>Table of Contents</b>	
1	Introduction	4
2	Safety Instructions	5
3	Specification	6
4	Installation	7
4.1	Positioning	7
4.2	Electrical Installation	7
4.3	Plumbing Installation	7
4.4	CO2 Installation	7
4.5	Backflow Prevention	9
4.6	Thermostat Setting	9
5	Overview & Operation	10
5.1	Before Using the Chiller	10
5.2	Display	11
6	Routine Maintenance	12
6.1	Daily Maintenance	12
6.2	External Parts	12
6.3	Cleaning	13
6.4	Sanitization	14
6.4.1	Preparing the Chiller for Sanitization	14
6.4.2	Sanitising	14
7	Accessing the Internal Components of the Chiller	15
7.1	How to Drain Water from the Ice bank	15
7.2	How to Remove the Top Panel	16
7.3	The Front Panel	16
7.3.1	How to Remove the Front Panel	16
7.3.2	How to Replace the Front Panel Assembly	18
7.4	The PCBs	19
7.4.1	Replacing the Display Board Assembly	19
7.4.2	Replacing the Water Leak Detection Board	19
7.5	Replacing the Pump	20
7.6	The Solenoid Valves	20
7.6.1	How to Remove the Solenoid Valve Bracket	20
7.6.2	How to Repair the Solenoid Valves	21

7.7	The Dustproof Net	22
7.8	The Gas Reducer	22
7.9	The Ice Bank Tank	23
7.9.1	Replacing the Cooling NTC & the Pressure Relief Valve	23
7.9.2	Replacing the Gas Board	24
7.9.3	Removing the Connectors Above the Tank	24
7.9.4	Replacing the Cooling Pump, Water Level Sensor and Sparkling Water Tank	26
7.10	Removing the Left Side Panel to Repair the Power Cable	27
7.11	Removing the Right Panel to Repair the Filter Connector Head	28
7.12	Removing the Cooling Switch	30
7.13	Accessing the Control PCB (1600406)	30
7.13.1	Repairing the Control PCB	31
7.14	Repairing the Fan (1400214)	32
8	Diagnostics	34
8.1	Troubleshooting Friia Lite Chiller/Carbonator P/N 1000202	34
8.2	Troubleshooting Friia Lite Chiller P/N 1000201	35
8.3	Failure Modes	36
9	Wiring Diagram	38
10	Hydraulic Diagram	39
11	Plumbing Diagram	40
12	Spare Parts	41
12.1	Spare Parts Diagram	41
12.2	Spare Parts List	42
13	Accessories	44

## 1 Introduction

The information provided in this manual is intended to assist in the installation and maintenance of the Marco FRIIA Lite System. Please read the instructions carefully to prevent accidents and ensure an efficient installation. This manual is not a substitute for any safety instructions or technical data affixed to the machine or its packaging. All information in this manual is current at the time of publication and is subject to change without notice. Only technicians or service providers authorized by Marco should carry out installation and maintenance of these machines. Marco accepts no responsibility for any damage or injury caused by incorrect or unreasonable installation and operation. Do not allow anyone to operate the equipment unless suitably trained. Keep the equipment in good working order and do not allow any modifications unless authorized by the manufacturer.

<p><b>WARNING:</b></p> <p>The refrigerant R600 (Iso-Butane) is flammable and it must be handled only by competent and responsible operators, under the conditions specified in the safety regulations in force.</p>	
<p><b>Risk of Fire / Flammable materials</b></p>	



<b>DO NOT SMOKE</b>	<b>NO NAKED FLAMES</b>
	

*Unless otherwise stated, pictures are generic and for reference only, they are subject to technical change without prior notice.*

*The manufacturer reserves the right to modify the product and the relative technical documentation at any time and without notification and cannot be held liable for any errors or inaccuracies in the contents of this manual.*

*This version of the use and Maintenance Manual describes the characteristics of the standard production equipment as of the date of printing.*

Contact Marco Beverage Systems for any technical queries or to order spare parts.

When replacing equipment parts, you are advised to use original spare parts; the manufacturer cannot be held liable for any reduction in equipment performance or damage caused by the use of non-original parts.

## 2 Safety Instructions

- Read all instructions.
- To protect against electric shock do not immerse mains cord in water or other liquid.
- To prevent fraying of the cable, do not let the mains cord hang over the edge of a table or counter; or touch hot surfaces.
- Do not operate any appliance with a damaged cord, plugs, or after the appliance malfunctions or has been damaged in any manner.
- Switch off at the mains (unplug or disconnect from outlet) and turn off the water supply when not in use and before cleaning. Allow to cool before removing components.
- The use of spares and accessories not recommended by Marco may cause damage and/or injuries.
- Do not use outdoors. Do not place on or near a hot gas or electric burner.
- Do not use the appliance for anything other than its intended use.
- Save these instructions.

### 3 Specification

Model	1000201	1000202
Description	FRIIA Lite Chiller	FRIIA Lite Chiller/Carbonator
Power Supply Voltage & Frequency (V/Hz):	230V ~ 50/60Hz	230V ~ 50/60Hz
Power Consumption:	177W	220W
Cooling capacity:	>12 L/h ( $\Delta T \geq 10^{\circ}\text{C}$ )	>12 L/h ( $\Delta T \geq 10^{\circ}\text{C}$ )
Pouvoir Hydrogène (PH)	6.5 ~ 8.5	6.5 ~ 8.5
Applicable Water Pressure	0.1 ~ 0.4Mpa	0.1 ~ 0.4Mpa
Room Temperature	4 ~ 38°C	4 ~ 38°C
Applicable Inlet Water	TDS<350ppm	TDS<350ppm
Chlorine Reduction	>97.4%	>97.4%
Carbonation tank Capacity	/	0.45L
Volume/Gas	/	>2.5V/gas
Sparkling water flow rate	/	$\geq 1.8\text{L}/\text{min}$
CO2 Reducer	/	Micro CO2 Reducer thread ACME
Rechargeable CO2 Bottle	/	60lt / 360-410gr
Cooling System	Ice Bank	Ice Bank
Cold Water Flow Rate	$\geq 1.5\text{L}/\text{min}$	$\geq 1.5\text{L}/\text{min}$
Cooling Power	100W	100W
Product Size	279x468x412mm (WxDxH)	279x468x412mm (WxDxH)

## 4 Installation

### 4.1 Positioning

- The equipment must be placed on a surface capable of bearing the weight of the chiller full of water. Install the equipment following the schematic described in this user guide.
- The chosen position must allow satisfactory ventilation; there must be a gap of at least 10 cm (3.9 in) around the back and top for ventilation.
- The equipment must not be placed close to direct or indirect heat sources (ovens, stoves, radiators, etc.).
- The electrical connection and water supply points must be close to the equipment must be located in such a way the power cable and water hose do not form an obstruction.
- The appliance must not be installed where water jets can be generated. Do not spray water on the device; this could cause electric shock or fires.
- The equipment is not suitable for external use.
- The equipment must be placed so it is protected from rain and water splashes, and in a location with the temperature appropriate to its climate class (stated in specification); otherwise, warranty rights are forfeited, and malfunctions may occur.

### 4.2 Electrical Installation

- When installing the chiller, always observe the local regulations and standards.
- The chiller is supplied with a moulded power cord.
- A suitable mains power supply socket should be available within easy access of the chiller so that it can be disconnected easily after install.

### 4.3 Plumbing Installation

- Ensure that the chiller is installed according to local plumbing & water regulations.
- Fit a stop valve on a cold-water line and attach a 3/8" BSP male fitting, (E.g. 3/4" x 1/2" 311 or washing machine type stop valve).
- Connect water supply lines following the installation drawings. As per installation guide in the User Manual (starting page 8).
- Push the pipe firmly into the fittings until locked into position to avoid leaks. 15mm is the correct depth of insertion.
- In case filter systems are used verify that they satisfy the requirements of the legislation in force.
- The chiller has a pressure reducer in case the incoming water exceeds 3 bar.
- Turn on the water to flush any impurities, dust etc. from the inlet hose and water pipe.
- Allow several litres through. Especially for new installations.

### 4.4 CO2 Installation

There are two CO2 installation options with this chiller, either an inbuilt 360-410gr/60L gas cylinder or an external CO2 cylinder.

#### **Internal gas cylinder**

Open the side door. Install the CO2 cylinder into the machine. A compatible gas cylinder to use is the Sodastream 60L cylinder <https://sodastream.co.uk/pages/co2-gas-cylinders> Once the CO2 cylinder is installed, the yellow CO2 light stops flashing on the front of the machine.

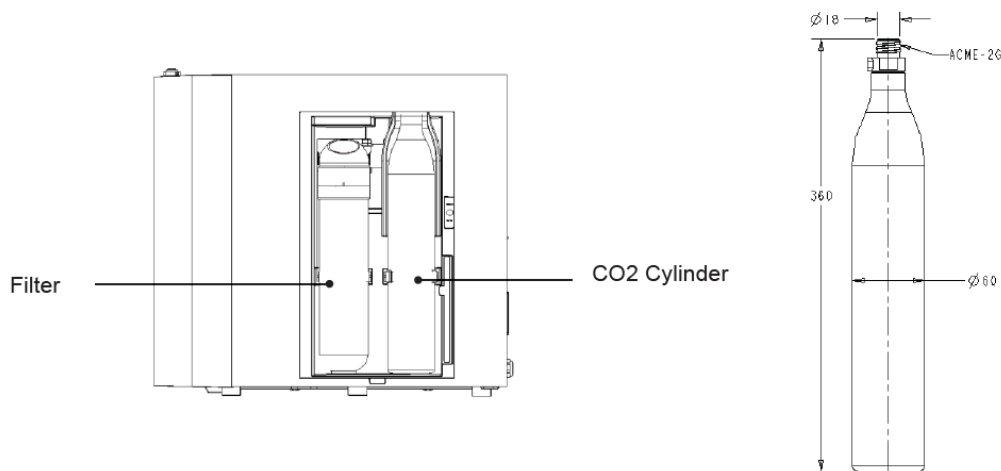

- **External gas cylinder**

The machine has an external gas connection for an 8mm hose (not provided) in the rear; you must supply appropriate pressure gas (0.4MPa). Only use super-dry, food grade CO2 hose. Before connecting the pressure reducer to the gas cylinder, always vent any dirt from the valve. Close the cylinder valve after a few seconds.

The cylinder must be replaced when the needle of the reducer high pressure gauge is in the red segment or when the CO2 light on the front of the chiller flashes.

1. Record the pressure values set on the pressure reducer, then fully close the bottle using the valve.
2. Remove the pressure reducer or disconnect the high-pressure hose from the bottle if fitted. Check the condition of the gaskets between the reducer and the bottle, replace them if necessary.
3. Replace the CO2 cylinder by slowly opening the valve to the fully open position and check that the pressure values are as originally set.

### **Gas cylinder location**

To prevent the risk of injury or damage the CO2 cylinder must always be kept in a vertical position against a wall, held in place by a chain and fixed to a bracket. Do not expose the bottle to heat sources or very low temperatures.

### **Pressure reducers**

There are different types of CO2 cylinder available. Always use a pressure reducer suitable for the type of valve on the cylinder. If you use CO2, especially in a small area, ventilate the contaminated area at once.

We advise using a Dual gauge CO2 regulator, Marco part number 1400195. Check for leaks using a solution of soapy water.



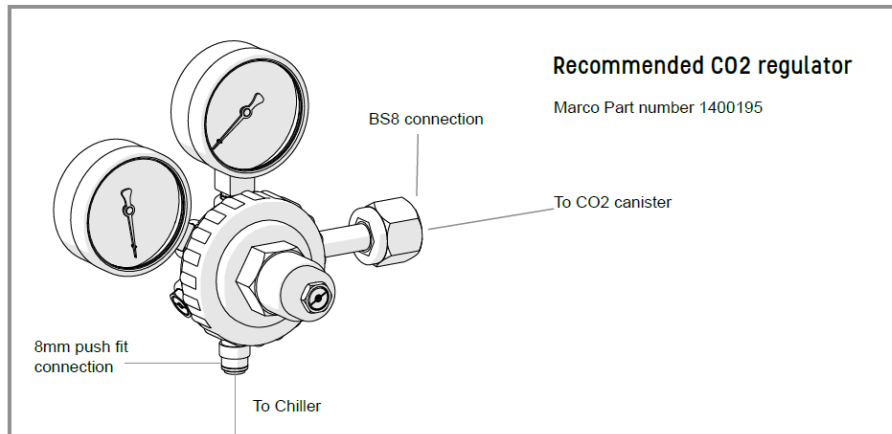

**1400195 (EU) - Dual Gauge CO2 Regulator 4.8bar (BS341 No8 (0.860" x 14tpi))**

**1860864 FEP Tubing 8mm OD for external gas supply**

#### 4.5 Backflow Prevention

This chiller must be installed with adequate backflow protection to comply with all applicable federal, state and local codes.

#### 4.6 Thermostat Setting

**The temperature of the dispensed beverages cannot be adjusted.**

## 5 Overview & Operation

### 5.1 Before Using the Chiller

- Before connecting the chiller to the power source, let it stand upright for approximately 2-3 hours, this will reduce the possibility of a malfunction.

- Check that all installation procedures have been carried out.

- Ensure water inlet is open.

Wait until the pump stops running before turning on gas or installing cylinder in the machine, to ensure the gas does not block the system.

- Ensure CO2 valve is open.

- Before supplying power to the chiller check water and CO2 lines do not leak.

- Plug the chiller into a suitable socket and turn the Cooling Switch on the rear of the chiller to the ON position.

- When the unit is on, the carbonation pump starts to fill. The carbonation device stops when it reaches the maximum level.

- If using an external CO2 Cylinder, on the pressure reducer knob, adjust CO2 pressure to a value between 50 and 65 PSI (350 and 450 kPa) (3.5 - 4.5 bar) This value depends on the temperature of the water and on the ambient temperature. The temperatures correspond to the CO2 pressure.





- The chiller will take approximately 70-120 minutes to get down to temperature depending on the temperature of your incoming water. The blue light on the front of the chiller remains flashing during this time.

- Once the blue light stops flashing and remains solid the water is chilled and at optimum temperature.

- To enable the filling of lines, push the front buttons in the following order sparkling water, cold water & hot water until the flows appear.

- At this point you can dispense water.

## 5.2 Display

Model	1000201	1000202
Description	FRIIA Lite Chiller	FRIIA Lite Chiller/Carbonator
Screen		
	<p>Filter Light</p> <p>Lights up to indicate the filter needs to be replaced. Flashing indicates a shortage of water.</p>	
	<p>Cooling Light</p> <p>Lights up to indicate the chiller is ready to use (allow 70 - 120min for the chiller to get down to temperature). Flashing indicates the compressor is ON.</p>	
		<p>Sparkling Water Light</p> <p>Lights up to indicate the CO2 Cylinder is empty. When the light is off this indicates the CO2 Cylinder is full of gas.</p>

## 6 Routine Maintenance

Maintenance should be carried out by Marco approved technicians only. Before undertaking routine maintenance on Friia Lite disconnect the machine from mains power, water and gas supply.

### 6.1 Daily Maintenance

#### 1. Water font

Clean the font nozzle and remove any residual using warm water; do not use solvents or abrasive detergents. If needed, remove all the limestone with a food descaling solution.

#### 2. Drip tray

Clean the drip tray and remove any residual using warm water.

#### 3. CO2 pressure

Review pressure CO2 gauges for proper settings.

#### 4. Power cord

Check the condition of the power cord. Replace if necessary.

### 6.2 External Parts

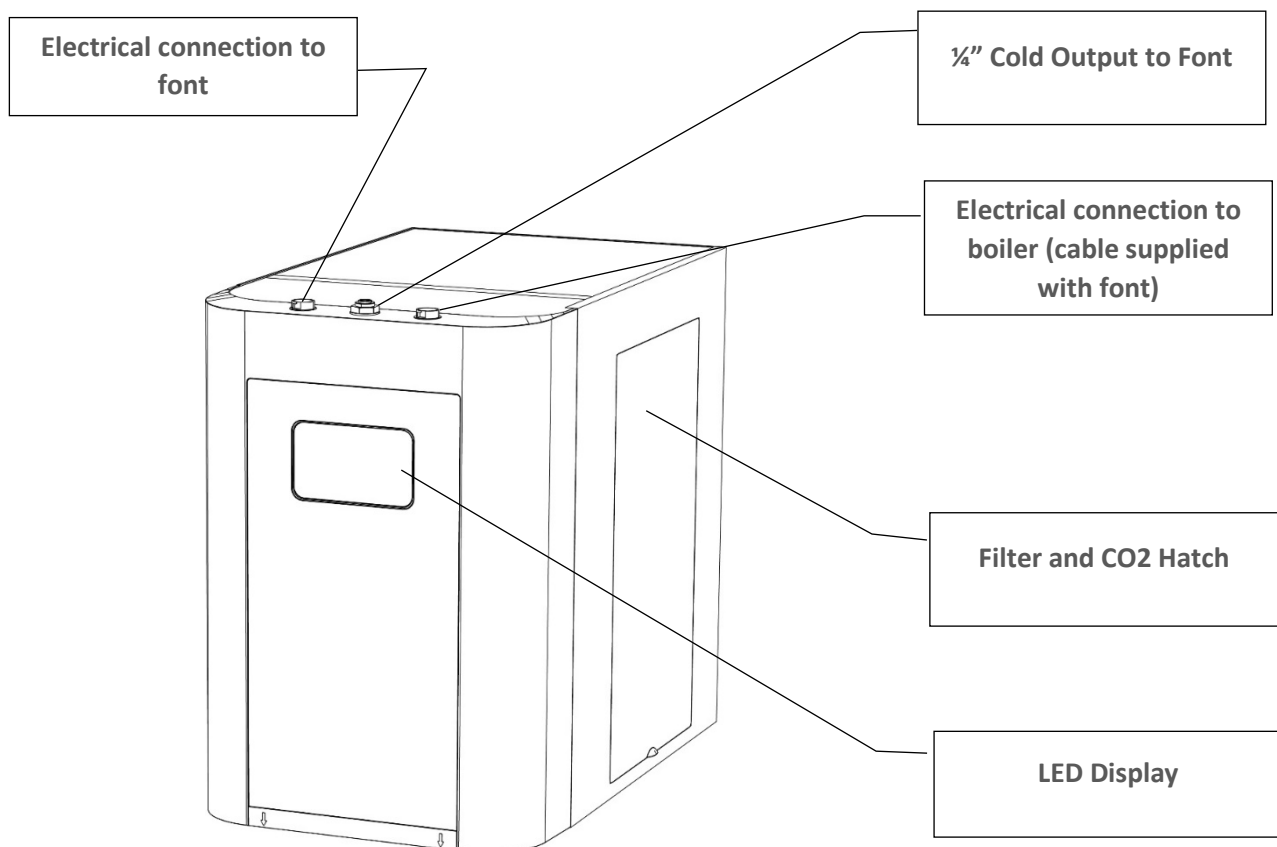

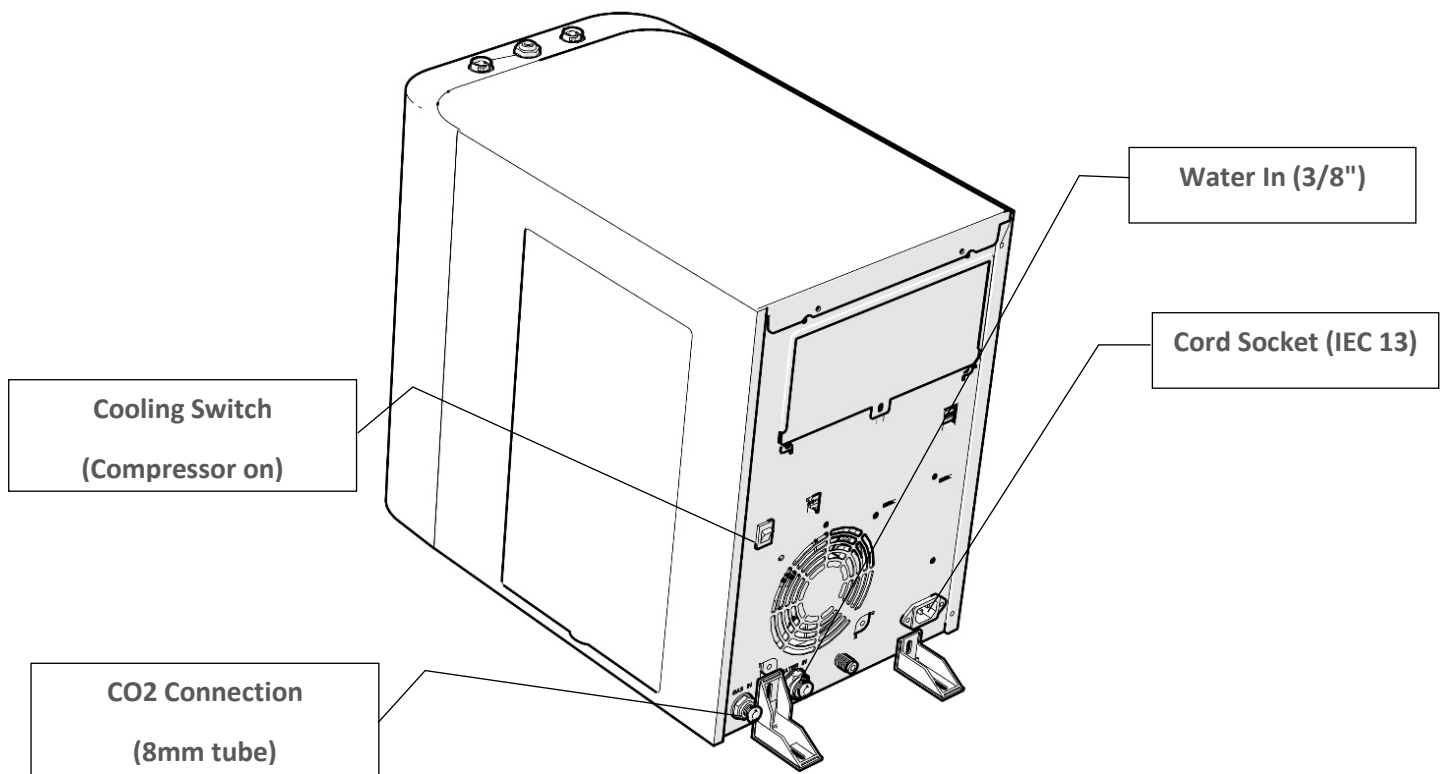

### 6.3 Cleaning

The exterior of these machines may be cleaned with a damp cloth and a light detergent. Do not use abrasive cloths or creams, as this will spoil the finish of the machine. Do not use a water jet or spray.

## 6.4 Sanitization

Sanitisation should be performed:

- every 6 months in use.
- after an inoperative period of one or more weeks.
- If the system is installed in Hospitals, Schools, Elderly people's homes, or Clinics, it is recommended to sanitise every 3 months.

Sanitisation to be performed using the following accessories:

**Need to add these once CO for sanitizing cartridge is raised and approved.**

### 6.4.1 Preparing the Chiller for Sanitization

1. Turn on water and flush at least 4 liters (1 gallon) through entire system (plain and carbonated water circuits).
2. Disconnect water line from main water supply.
3. Dispense both plain and carbonated water, until only CO<sub>2</sub> is dispensed.
4. Close the CO<sub>2</sub> cylinder and dispense carbonated water to remove CO<sub>2</sub> pressure completely.

### 6.4.2 Sanitising

1. Turn off Electrical Power Supply.
2. Turn off the Cooling Switch on the back of the unit to turn the compressor off.
3. Replace the filter cartridge with a sanitizing filter recommended by Marco and fill with clean water and with sanitizing fluid in the concentration and contact time recommended by the manufacturer.
4. Disconnect the water connections and connect them to the sanitization cartridge.
5. Turn on water mains and power supply mains.
6. DO NOT TURN ON COOLING SWITCH AT THIS TIME
7. Flush all lines (Cold and Sparkling) with sanitizer by pressing the buttons on the FRIIA font until you can smell the sanitizing product which may have a characteristic smell, or colour. Colorimetric test strips can also be used to make sure the entire line is filled with the sanitizing liquid.
8. NOTE: A container and drain basin will be required to collect water from the FRIIA font.
9. Be careful: respect the sanitiser concentration and contact time recommended by the manufacturer; using extra liquid will neither improve nor speed up the treatment process.

## 7 Accessing the Internal Components of the Chiller

1. Disconnect the machine from the electrical supply.
2. Disconnect all water and CO2 connectors.
3. Purge the CO2 from the machine, using the font.
4. Release the BOILER and FONT harness connection.
5. Drain the machine of water. Please note the ice bank needs to be defrosted before fully draining the machine.

### 7.1 How to Drain Water from the Ice bank

**Note: The ice bank needs to be defrosted before fully draining the machine**

Press the 2 plastic snap fasteners to remove the front panel bottom cover. Remove the blue plug and store safely. Replace the blue plug when the machine is completely drained.



## 7.2 How to Remove the Top Panel

To remove the top panel undo 2 Phillips Screws. Then carefully remove the lid, pulling the lid towards the back of the chiller. See images below.



## 7.3 The Front Panel

### 7.3.1 How to Remove the Front Panel

Before removing the front panel, both the front panel bottom cover (7.1) and the top panel (7.2) need to be removed. Once these panels have been removed, remove the two Phillips screws on the bottom of the front panel, see image below..





Then remove the two screws on the top of the chiller.

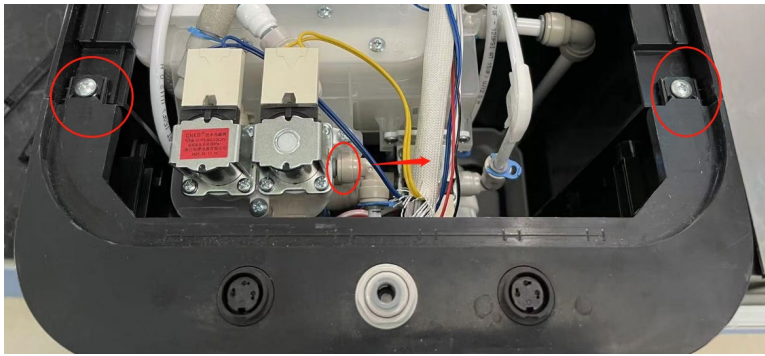

Remove the bracket

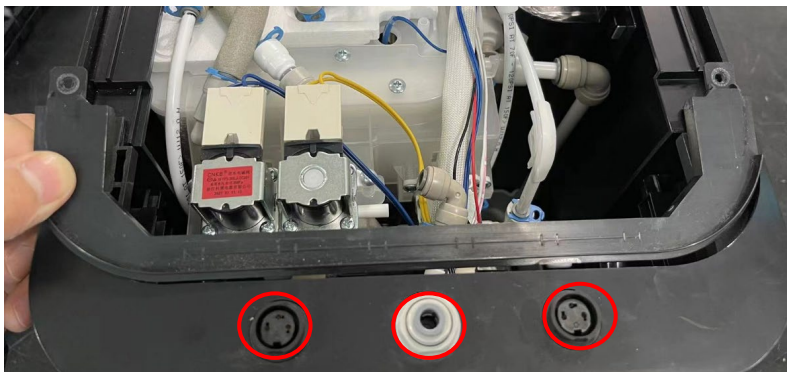

Disconnect the cold water pipe and two electrical on the front of the top panel before attempting to remove the front panel.

Lift the front panel up vertically and then pull forward gently, to release the brackets holding the panel in place. Disconnect the wiring harness going to the display PCB on the front panel before removing the panel fully.

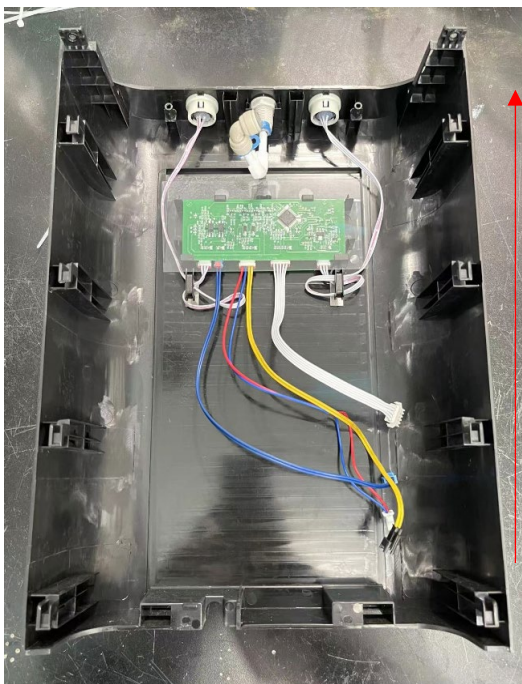

### 7.3.2 How to Replace the Front Panel Assembly

#### 1. Removing the binder connector

- Pull to move the Buckle

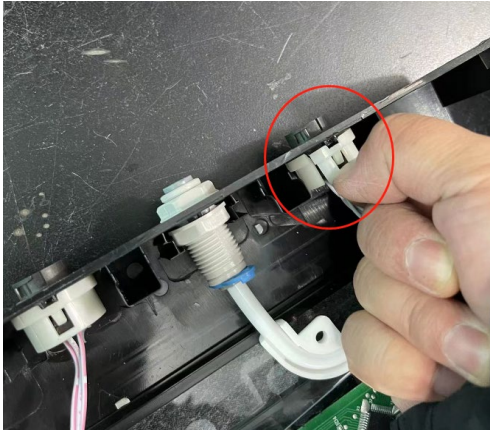

#### 2. Removing the water outlet

- Turn the nut counterclockwise

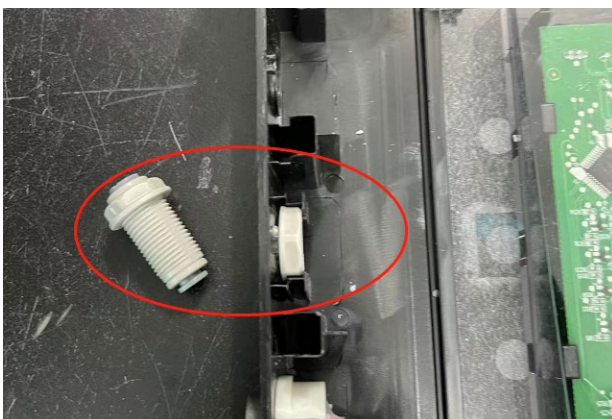
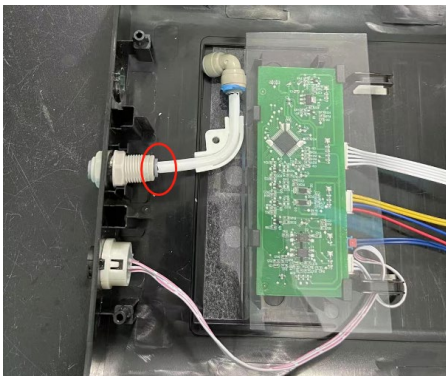



## 7.4 The PCBs

### 7.4.1 Replacing the Display Board Assembly

Unclasp the 2 snap- fits.

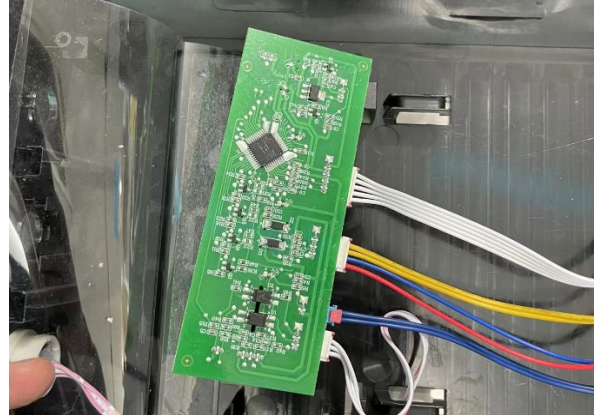
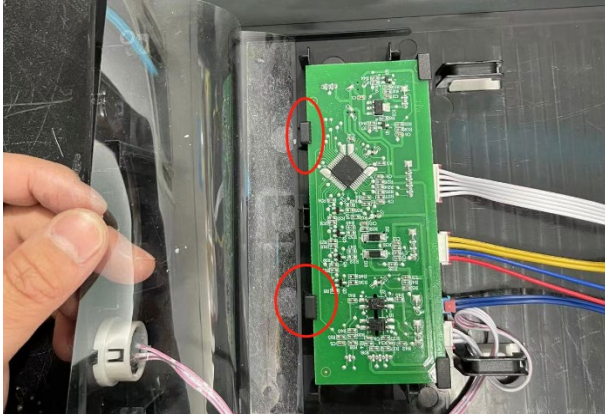

### 7.4.2 Replacing the Water Leak Detection Board

Unclasp the snap- fit circled in red below and then remove the PCB.

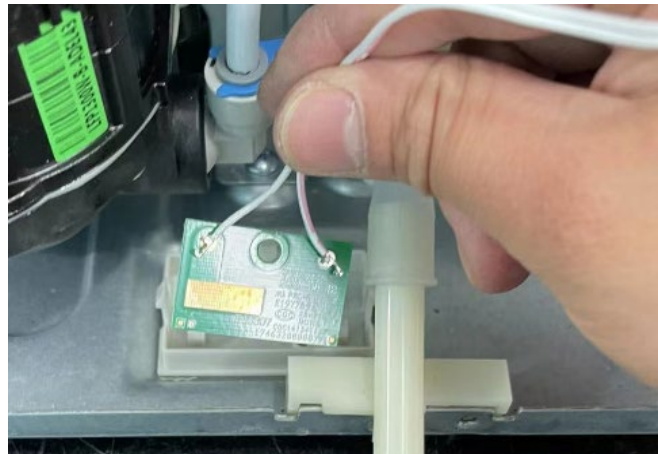
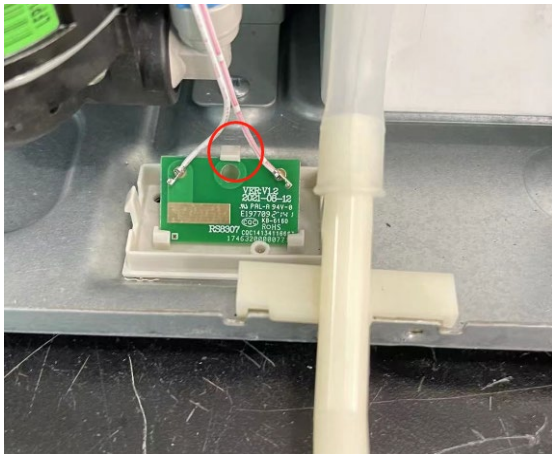

## 7.5 Replacing the Pump

1. Disconnect the water in and water out pipes.
2. Remove the x4 screws on the pump. Take due care due to the weight of the pump.
3. Unclip the pump wiring harness at the top of the pump.

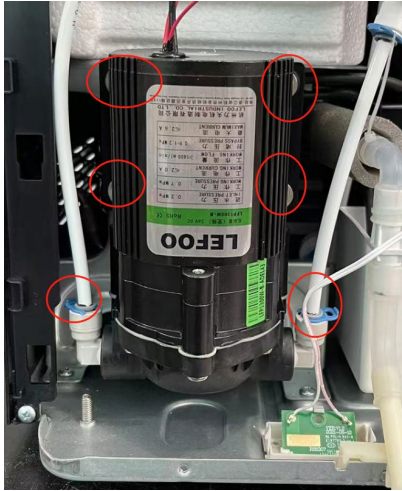

## 7.6 The Solenoid Valves

### 7.6.1 How to Remove the Solenoid Valve Bracket

Remove the 3 screws circled in red below.

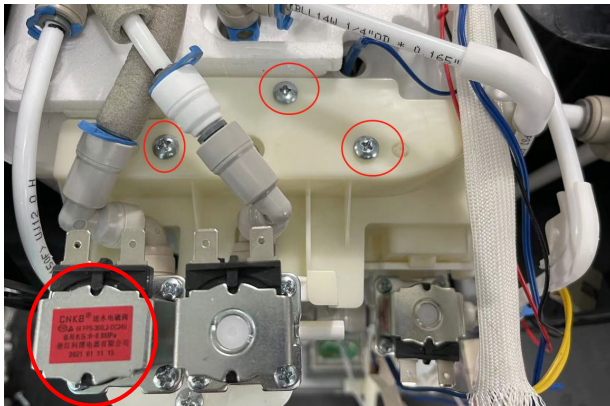

1502177 - water-out solenoid valve (left side side)

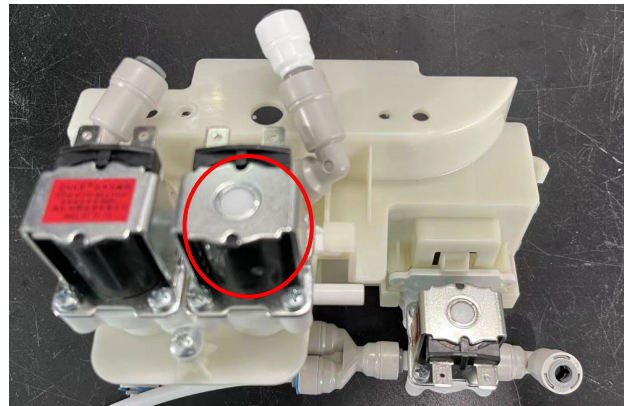

1502178 – water-in solenoid valve (right side)

## 7.6.2 How to Repair the Solenoid Valves

Pull out the connector and remove the screw highlighted in red in the image below.

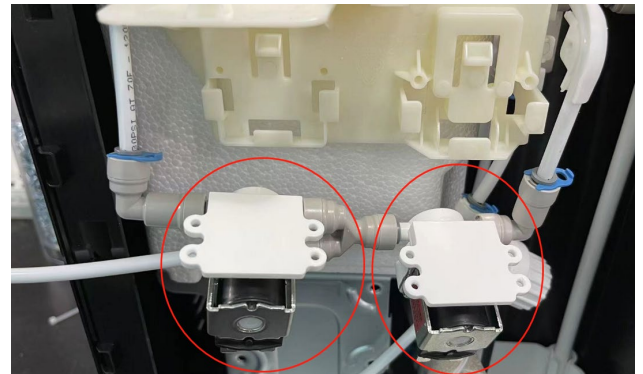
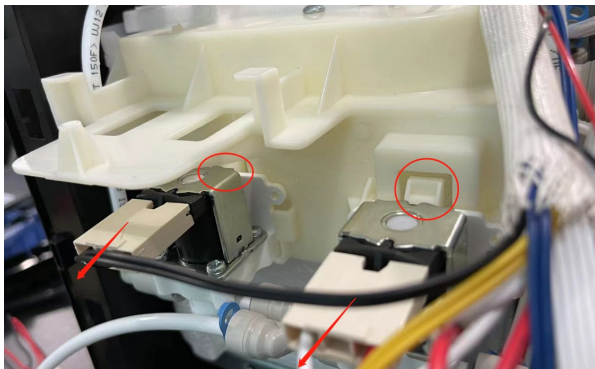
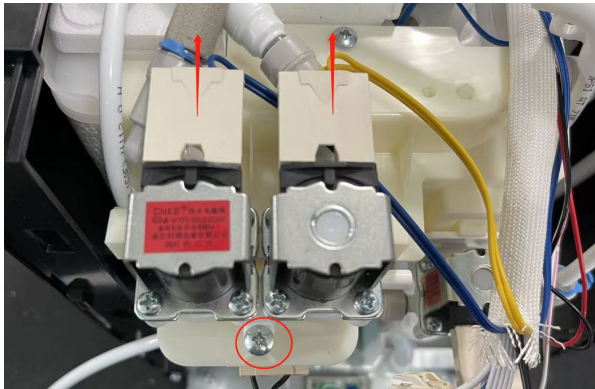



### 7.7 The Dustproof Net

To clean the dustproof net, open the filter hatch door and slide out the mesh filter and clean it.



### 7.8 The Gas Reducer

To replace the gas reduce remove the 4 outer screws.

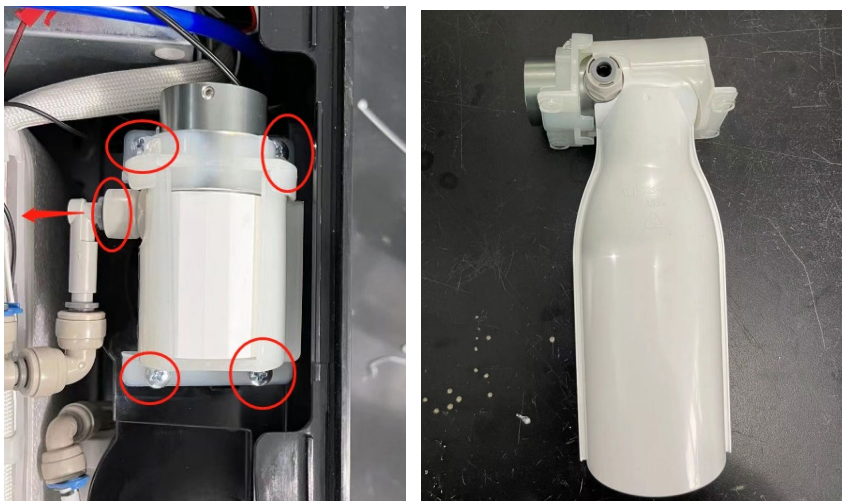

Then remove the 2 internal screws, highlight in red below.



## 7.9 The Ice Bank Tank

### 7.9.1 Replacing the Cooling NTC & the Pressure Relief Valve

Locate the NTC (Marco P/N. 1400213) on the top of the ice bank, highlighted in red below.

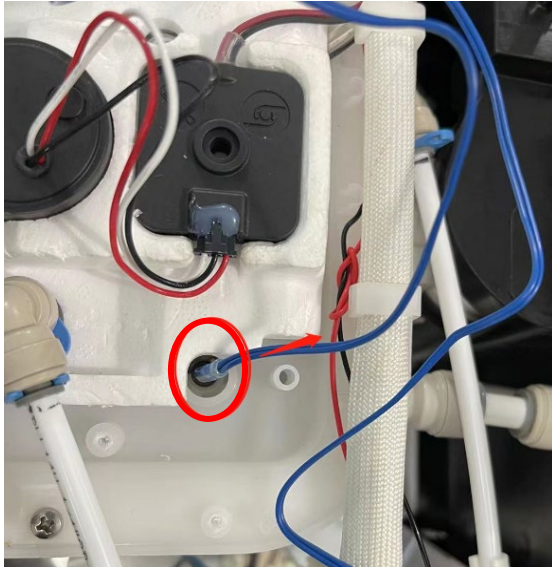

Pull out the NTC out of the ice bank.

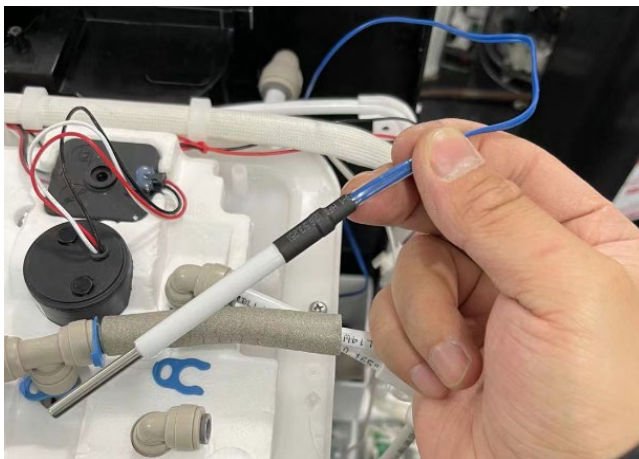

Pull out the pressure relieve valve (Marco P/N. 1400205), highlighted in red below.



### 7.9.2 Replacing the Gas Board

To replace the gas board, remove all the screws, as per the images below.

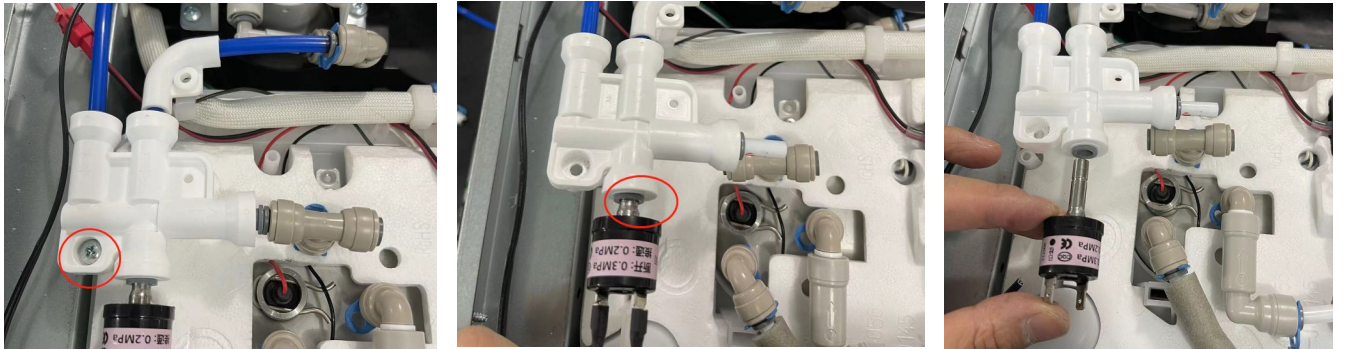

### 7.9.3 Removing the Connectors Above the Tank

To access the carbonation tank all the connectors highlighted in red below need to be removed.

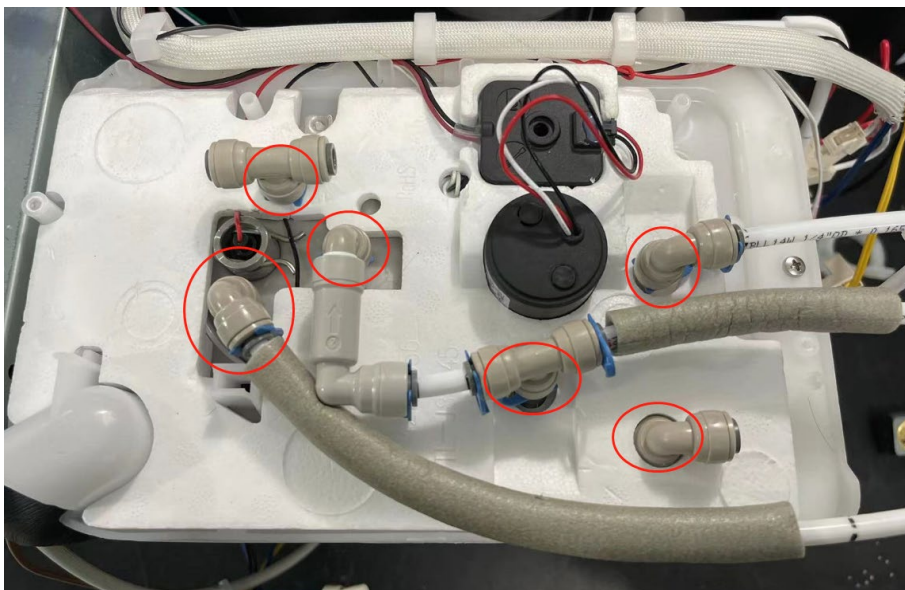



The image below shows the top of the carbonation tank with all the connectors removed.

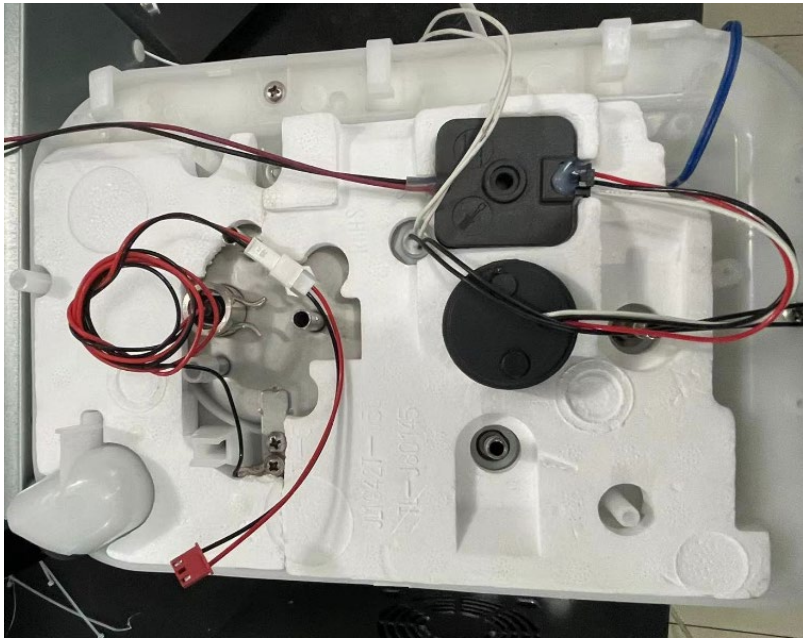

After the connectors are removed the foam insulation (Marco P/N. 2000013) needs to be removed.

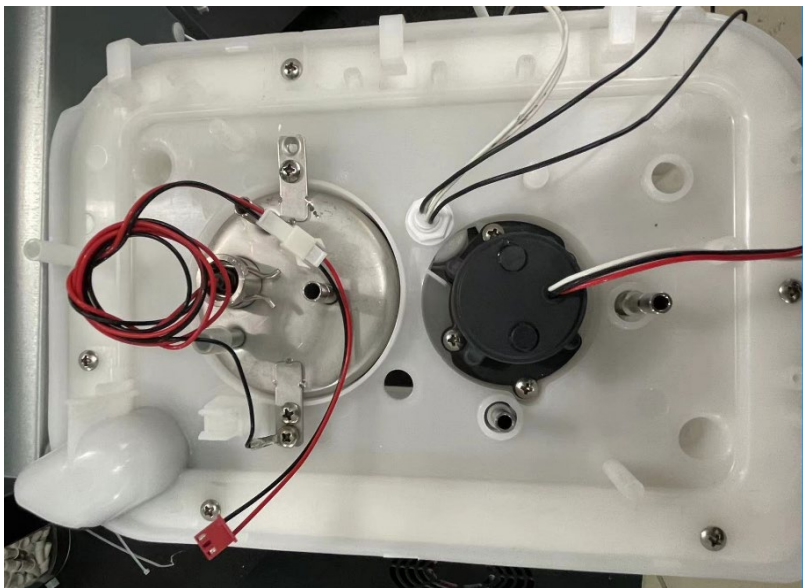

#### 7.9.4 Replacing the Cooling Pump, Water Level Sensor and Sparkling Water Tank

Firstly, remove the cooling pump (Marco P/N 1400207) by removed the 3 screws highlighted in red below and pulling the pump out of the carbonation tank.

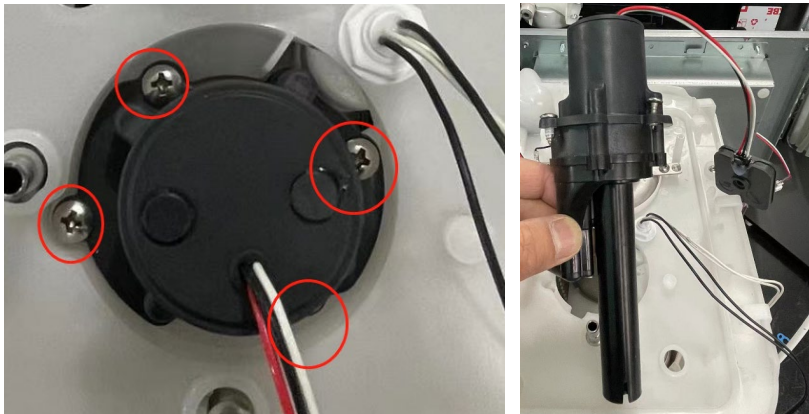

Once the cooling pump is removed you can remove the water level sensor (Marco P/N 1600412), see images below.

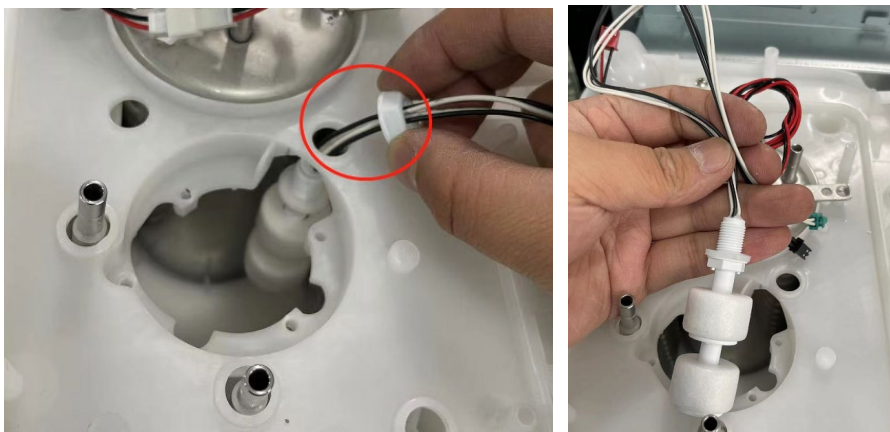

Then the carbonation tank can be removed, Please note the carbonation tank is not sold as a spare part.

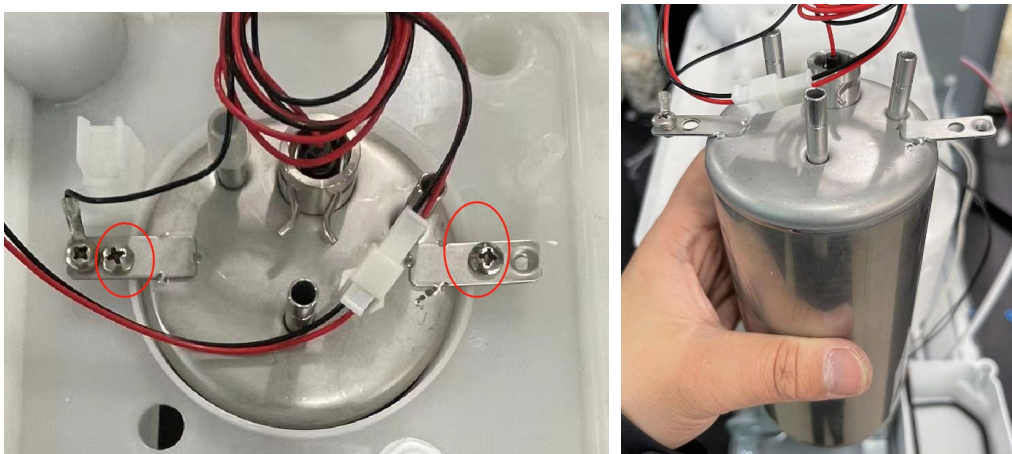

## 7.10 Removing the Left Side Panel to Repair the Power Cable

The left side panel of the chiller is removable to access the wiring harness that goes to the power board at the back of the chiller.

1. Remove the 1 screw on the front of the left panel.

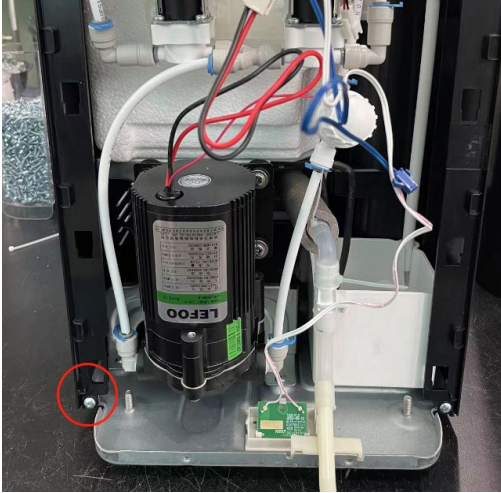

2. Remove the 2 screws on the back of the left panel.

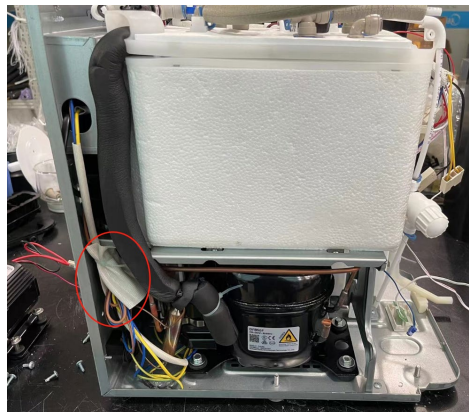

Disconnect the wire connectors of the compressor and fan, see image below.





3. Remove the 2 screws on the IEC Socket (Marco P/N. 1501529).

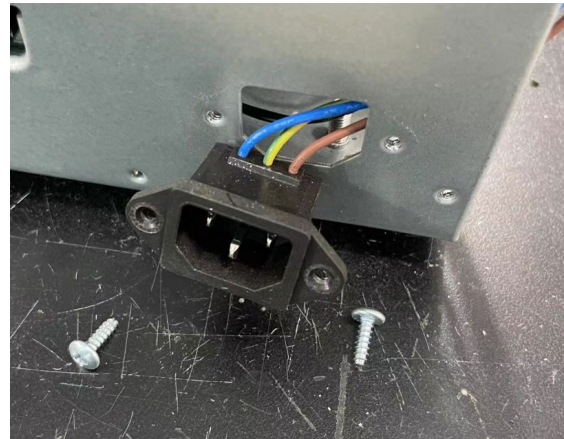
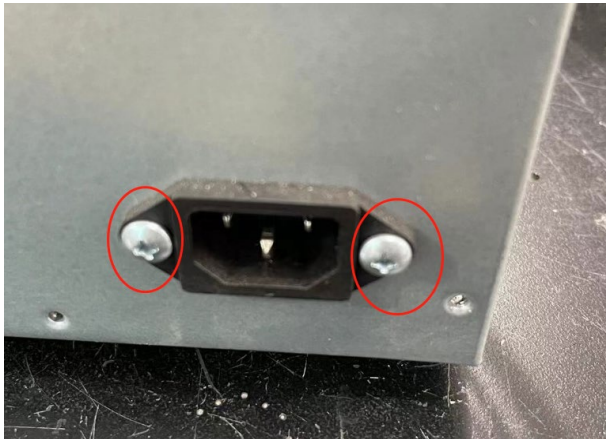

### 7.11 Removing the Right Panel to Repair the Filter Connector Head

1. Remove the 1 screw on the front of the right panel.



2. Remove the 2 screws on the back of the right panel.



3. Remove the filter reset board (Marco P/N.1600411) and water-in pipe.

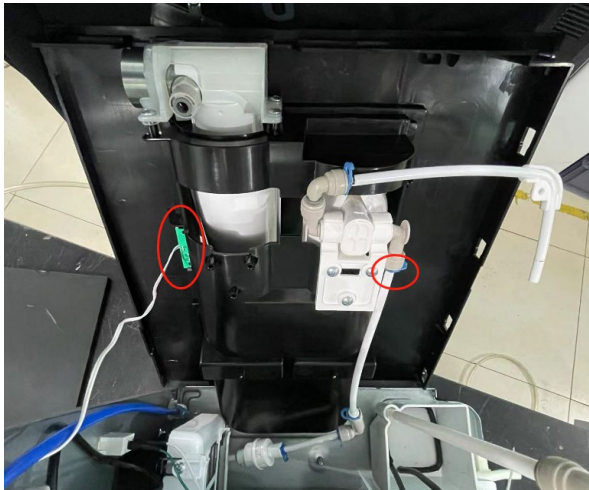

4. Remove the 3 screws

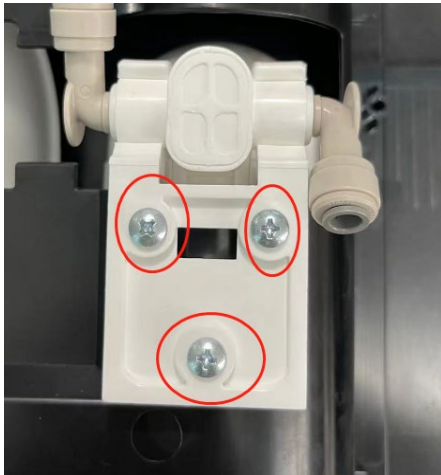

## 7.12 Removing the Cooling Switch

1. Remove the 2 wire connectors at the back of the cooling switch. Replace the cooling switch (Marco P/N. 1400206).



## 7.13 Accessing the Control PCB (1600406)

Remove the screw in the center of the rear panel and the PCB panel cover should slide out of the slot.



The Marco P/N for the PCB is 1600406.

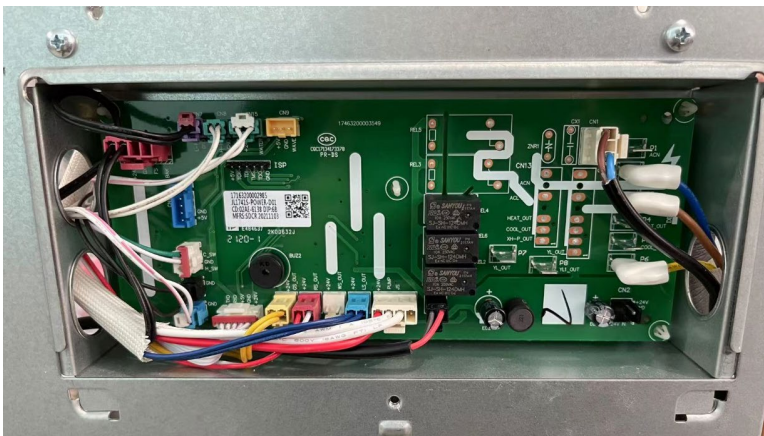



### 7.13.1 Repairing the Control PCB

1. Remove the 2 screws above the PCB.

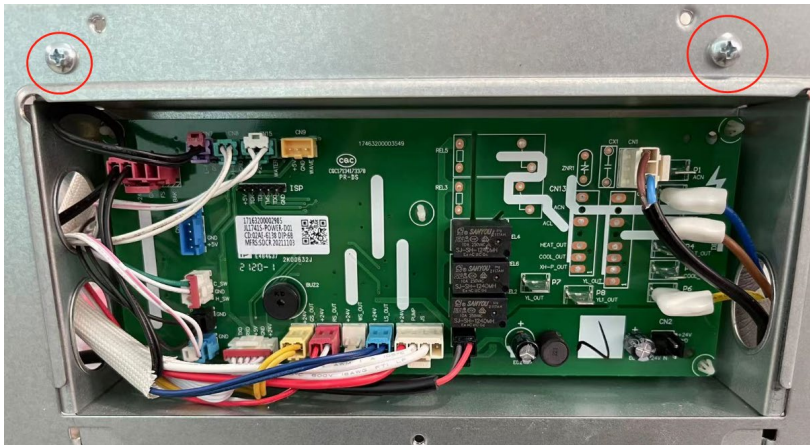

2. Remove the 3 power wire connectors (yellow, brown & blue wire) on the right of the PCB.

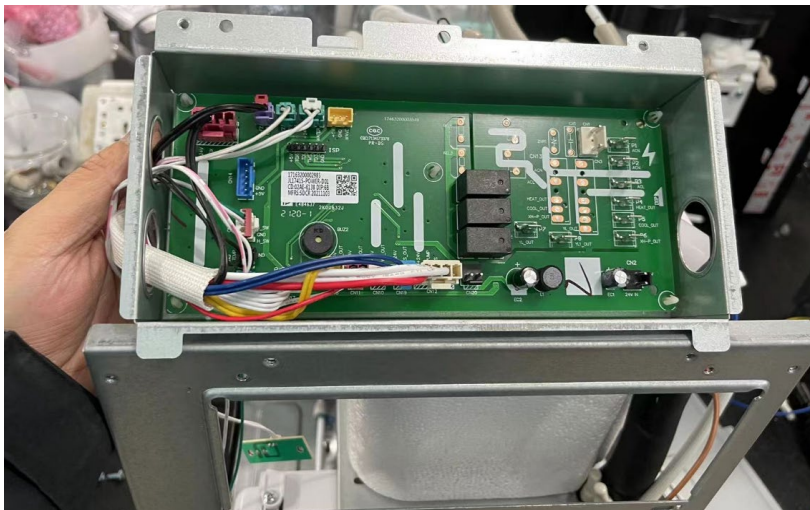
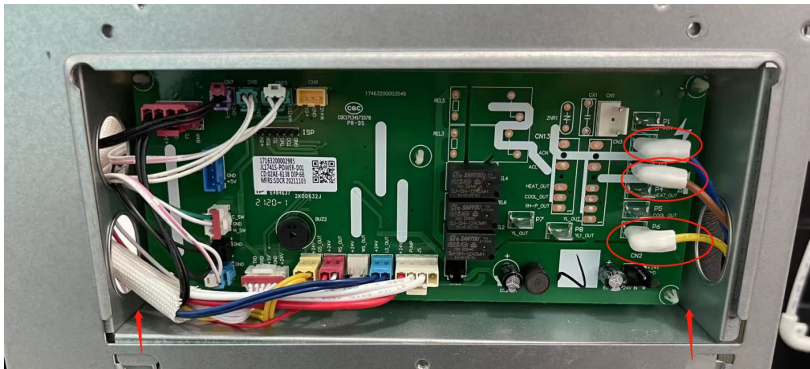

## 7.14 Repairing the Fan (1400214)

1. Remove the two screws highlighted in red below on the back panel of the chiller.

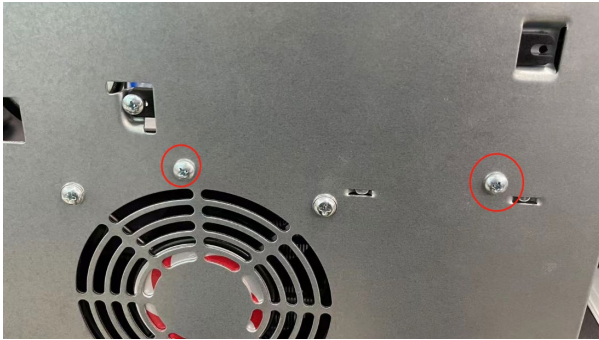

2. Lift the fan out of the buckle

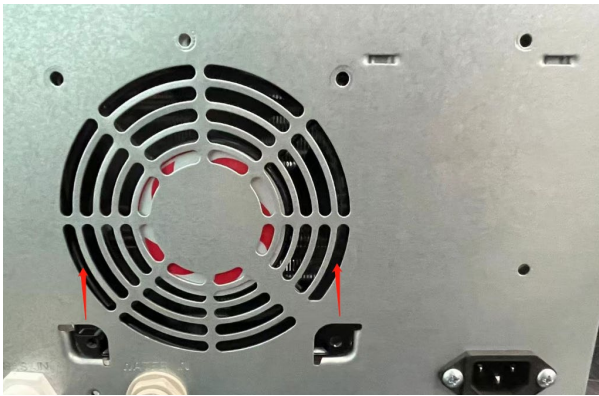

3. Pull the fan (Marco P/N. 1400214) out carefully

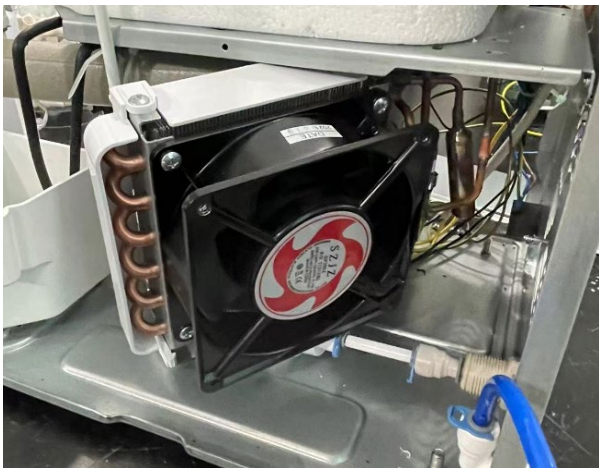



4. Remove the 4 screws with a 4mm screwdriver

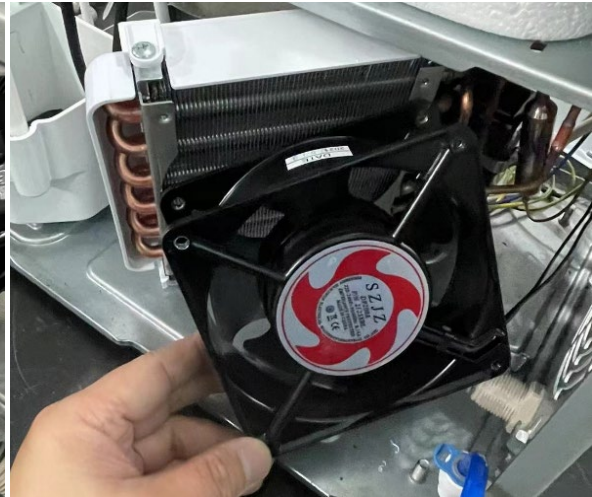
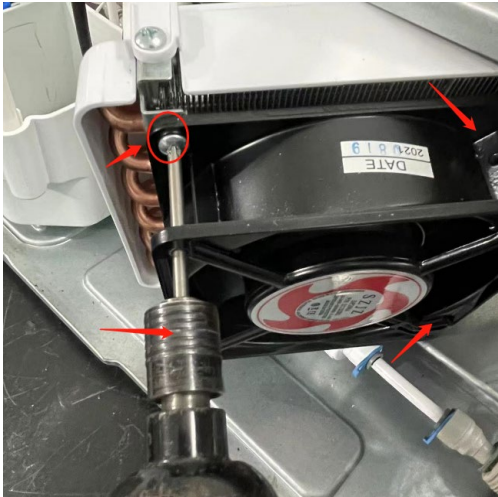

## 8 Diagnostics

### 8.1 Troubleshooting Friia Lite Chiller/Carbonator P/N 1000202

				●	Illuminated
					Flash
				○	OFF
Product 1000202	Filter	Cooling	Cylinder	Cause	Solution
	-RED	-BLUE	-YELLOW		
Power ON + Cooling ON + Cylinder FULL	○		○	Normal	
Power ON + Cooling ON + Cylinder EMPTY	○		●	CO2 reminder	Replace the cylinder
Power ON + Cooling finished + Cylinder FULL	○	●	○	Normal	
Power ON + Cooling finished + Cylinder EMPTY	○	●	●	CO2 reminder	Replace the cylinder
Filter reminder + Cooling ON + Cylinder FULL	●		○	Filter needs replacing	Replace the filter, reset the filter recover button (located beside filter)
Filter reminder + Cooling ON + Cylinder EMPTY	●		●	Filter & CO2 reminder	Replace the filter ,reset the filter recover button. Replace the cylinder
Filter reminder + Cooling finished + Cylinder FULL	●	●	○	Filter needs replacing	Replace the filter, reset the filter recover button (located beside filter)
Filter reminder + Cooling finished + Cylinder EMPTY	●	●	●	Filter & CO2 reminder	Replace the filter, reset the filter recover button. Replace the cylinder
Cooling switch off. Or Refrigeration system problem	○	○	○	Cooling switch off. Or cooling NTC fault.	Turn on the cooling switch. Then check it and replace the NTC in the ice bank
No water in Icebank		○	○	Shortage of water	Check the water supply

Pump continues work exceed 5min without operation		○	○	No water in the cold pipes	Check the water supply
Water leakage				Water leakage	Power off. Check all pipes and connectors.
Water Overfilling in Icebank	●	○	○	Water leakage	Power off. Check all pipes and connectors. Drain water in the icebank tank.

## 8.2 Troubleshooting Friia Lite Chiller P/N 1000201

Product 1000201	Filter - Red	Cooling - Blue	Cause	Solution
Power ON + Cooling ON	○		Normal	
Power ON + Cooling Finished	○	●	Normal	
Filter reminder + Cooling ON	●		Filter needs replacing	Replace the filter, reset the filter recovery button (located beside filter)
Filter reminder + Cooling finished	●	●	Filter needs replacing	Replace the filter, reset the filter recover button (located beside filter)
Refrigeration system problem	○	○	Cooling NTC fault	Check and replace the cooling NTC in the ice bank
No water in Icebank		○	Turn off Refrigeration system and pump until water is full	Waiting for the machine purifying water
No water in Icebank exceed 10min		○	Shortage of water	Check the water supply. Press any button resume
Water leakage			Water leakage	Power off Check all pipes and connectors
Overfilling in Icebank	●	○	Overfilling in Icebank	Power off Drain water in icebank

### 8.3 Failure Modes

Failure	Cause	Solution
	Low water pressure	Check the tap water
	Filter not replaced in time, beyond the use time	Replace the filter
Unsuitable water temperature	Over consumption of water in a short time	Wait a moment, and water is available again
	The cooling switch is not turned on	Turn on the cooling switch at the rear of the machine
Water leakage	Pipe not connected properly	Inspect the connector to connect the pipe properly
	Water pipe and PE pipe bursting	Replace the water pipe and PE pipe
Electric leakage	Machine in poor contact with ground	Use a socket with earth wire, making the machine grounded properly
Noisy operation	Not installed steadily or levelled	Place the machine on a steady & solid surface; level the machine
	A few pipes are touching some parts inside the appliance, thus causing it to vibrate	Adjust the position of pipes, making sure they don't touch any other parts
Machine fails to run	Power supply not put through	Switch on power supply
The compressor will not start	Power failure	Check that there is voltage in the plug
	The compressor is faulty	Replace it
The water is cold but the compressor is working continuously or non- stop	Little ventilation	Replace the appliance away from the wall
	The condenser is dirty or covered	Clean the condenser or free it of its obstacles
	The room temperature is higher than 40 °	It's normal that the appliance works at a continuously high room temperature
The compressor works continuously, but the water is not cold	Gas leak from the cooling system	Contact a refrigeration engineer
	The compressor is faulty	Replace the compressor.
Cold water comes out slowly or not at all	Clogged water filter	Replace the filter pump
	The pump is blocked	Check it and replace the
The soda water is not very fizzy or not at all	The pressure of CO2 reducer is set less than 4 bars	Check and replace the gas reducer

Only gas comes out of the carbonated water outlet	The pump is blocked	Check and replace the pump connected to the water in pipe of the carbonation tank
	There is no water in the line	

## 9 Wiring Diagram

Awaiting latest wiring diagram from Midea

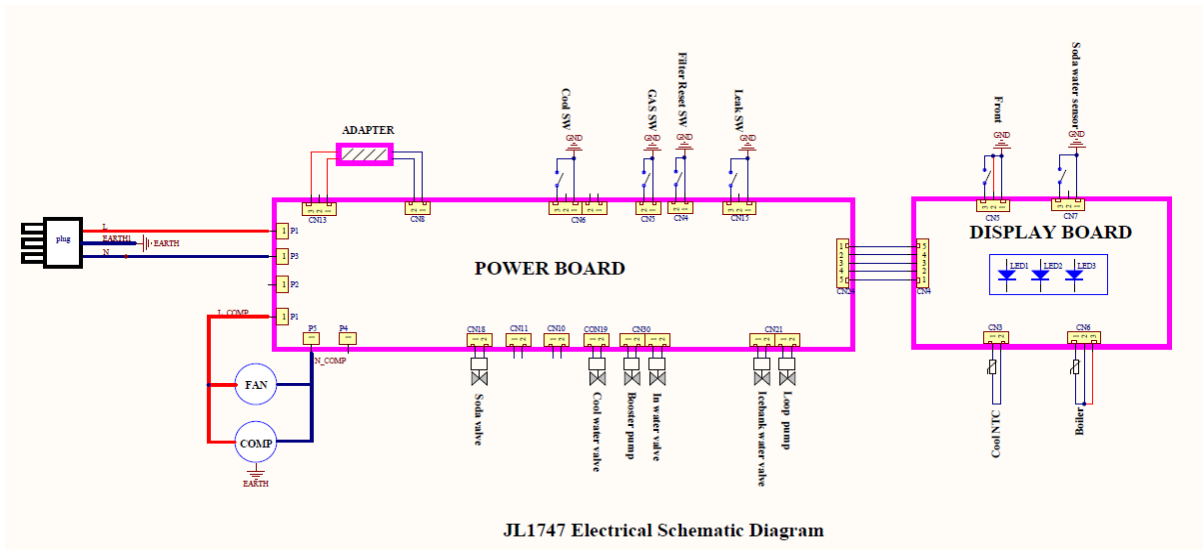

JL1747 Electrical Schematic Diagram

# 10 Hydraulic Diagram

Awaiting better image from Midea

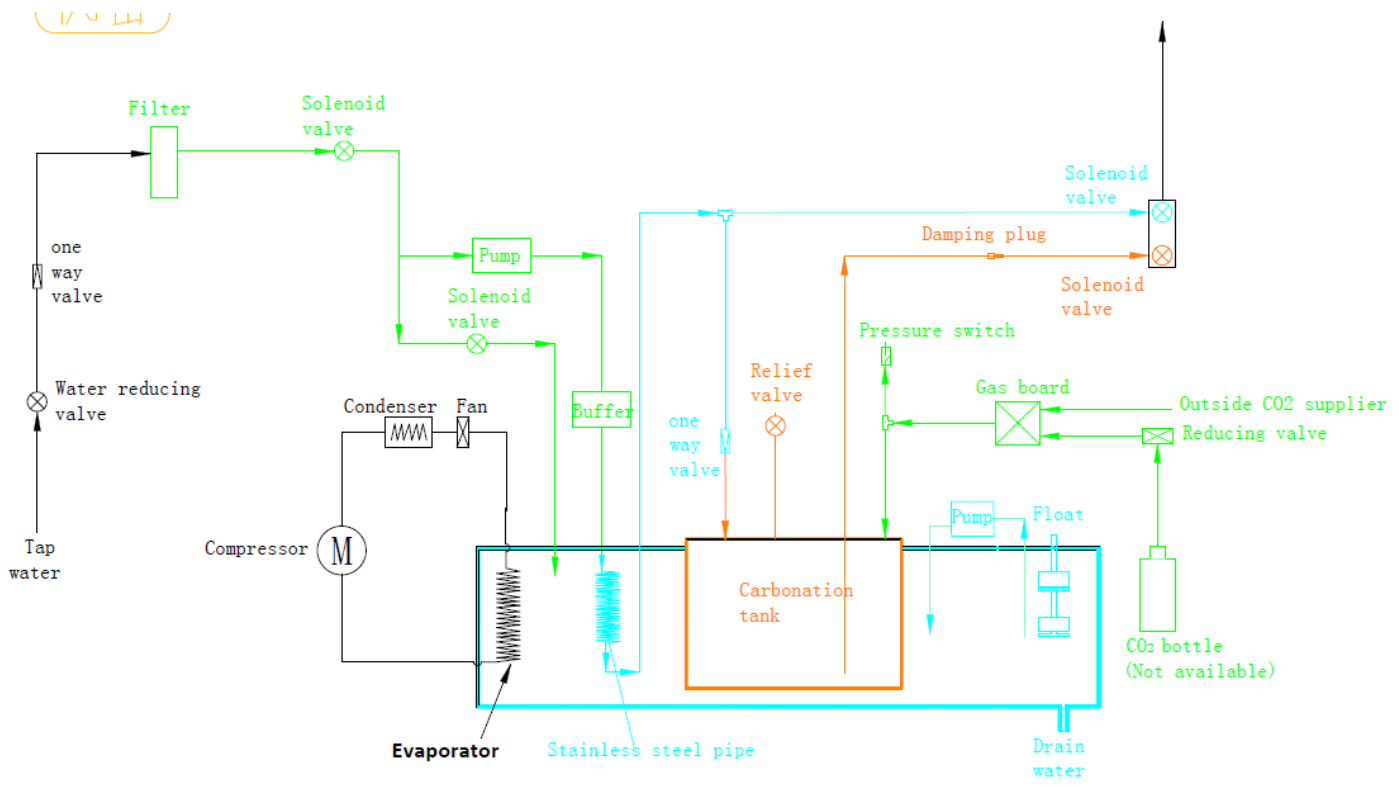

# 11 Plumbing Diagram

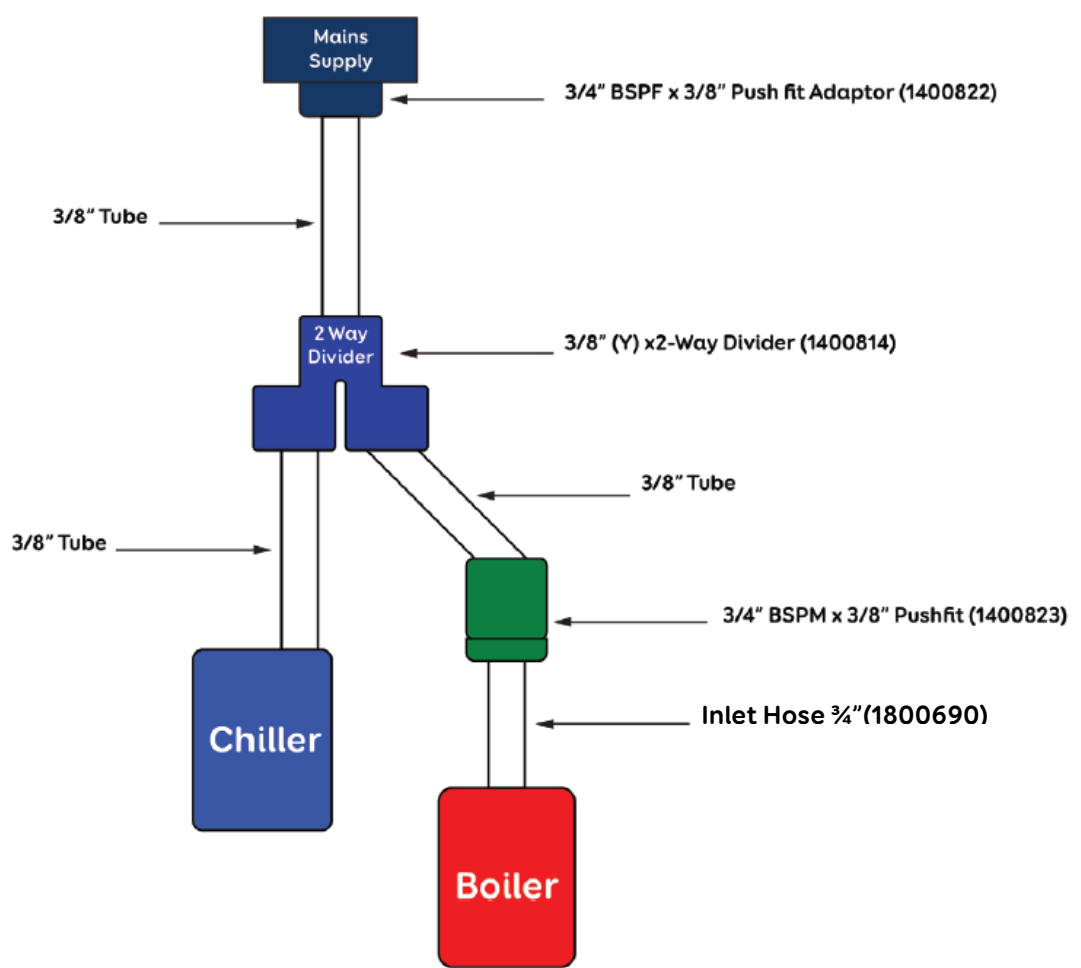



## 12 Spare Parts

### 12.1 Spare Parts Diagram

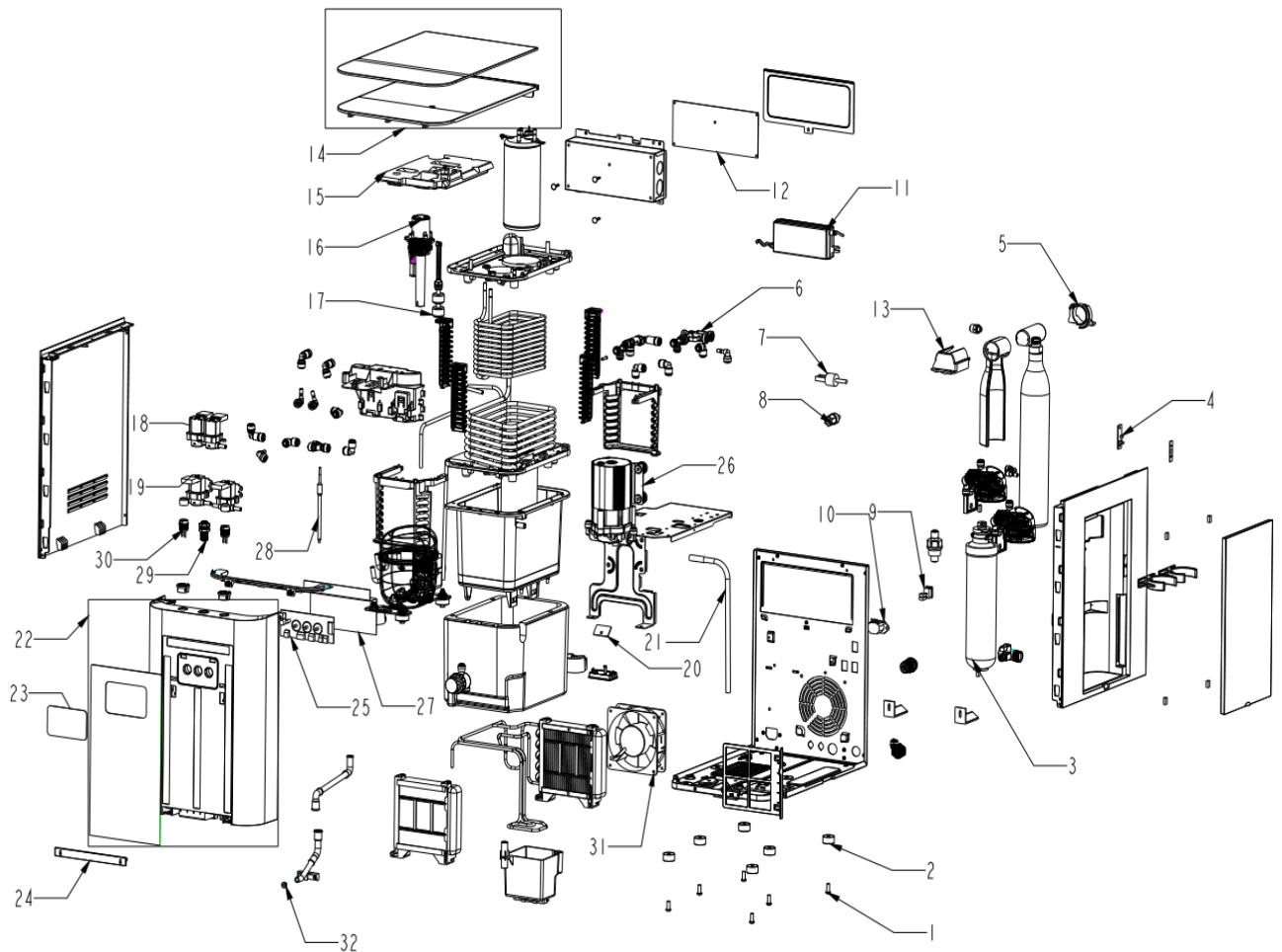

## 12.2 Spare Parts List

No.in Exploded-view	Name	Midea Code	Marco Part Number	Qty per Machine 1000201 (Cold)	Qty per Machine 1000202 (Sparkling)
1	Foot Screw Friia Lite	12963200000361	1400201	6	6
2	Foot Friia Lite	12663000000368	1400202	6	6
3	PAC Filter Friia Lite	15663200A05863	1400216	2	1
4	Filter Reset PCB Friia Lite	17163100000901	1600411	1	1
5	Gas Reducer Bracket Cover Friia Lite	12163100002304	1400203	0	1
6	Gas Board Friia Lite	12163200017753	1600409	0	1
7	Pressure Switch Friia Lite	17463100001084	1400204	0	1
8	Pressure Relief Valve Friia Lite	12963100001402	1400205	0	1
9	Cooling Switch Friia Lite	17463100A00103	1400206	1	1
10	IEC Socket Panel Mount Friia Lite	11201704006226	1501529	1	1
11	Adaptor 230V to 24V Friia Lite	17163200004707	1501532	1	1
12	Power Board Friia Lite	12263200002521	1600406	1	1
13	Gas Reducer Bracket Base Friia Lite	12163100002056	1400217	0	1
14	Top Panel Friia Lite	12163200018302	1400218	1	1
15	Insulation Foam Top Friia Lite	12463100000081	2000013	1	1
16	Circulation Pump Friia Lite	17463100002908	1400207	1	1
17	Float Switch Friia Lite	11201005000650	1600412	1	1
18	Solenoid Valve Water Out Friia Lite	17463200004751	1502177	1	1
19	Solenoid Valve Water In Friia Lite	17463200000060	1502178	2	2
20	Water leak PCB Friia Lite	17163200000190	1600413	1	1

21	Overflow pipe Friia Lite	12663200005187	1400219		
22	Front Panel Friia Lite	12163100005301	1400221	1	1
23	Front LED Panel Friia Lite C/S	16063000002905	1400222	0	1
	Front LED Panel Friia Lite C/only	16063000002906	1400223	1	0
24	Front Panel Bottom Cover Friia Lite	12163100005183	1400209	1	1
25	Display PCB Friia Lite Cold Only	17163100005528	1600414	1	0
	Display PCB Friia Lite Cold & Sparkling	17163100004948	1600408	0	1
26	Booster Pump Friia Lite	11001012000551	1400211	1	1
27	Display Board Back Cover Friia Lite	12176000021403	1400212	1	1
28	Cooling NTC Friia Lite	17463100003665	1400213	1	1
29	Water Outlet connecter Friia Lite	12163200000366	1501533	1	1
30	Binder Connector Harness Friia Lite	17463100004406	1501534	2	2
31	Fan Friia Lite	17463200008673	1400214	1	1
32	Drain Plug Friia Lite	12663000000358	1400215	1	1
33	Gas reducer Friia Lite	12963100001401	1400224	0	1
34	Gas reducer connector Friia Lite	12163100002301	1400225	0	1

### 13 Accessories

The following accessories come in the box with the chiller.

Part	Qty	Image	Marco PN
3/8" Tube (water into chiller)	2M		1400834
3/4" BSPF x 3/8" Push fit Adaptor	1		1400822
Boiler - chiller cable <b>IN BAG</b>	1		1501180
User manual <b>IN BAG</b>	1		1900960
EU Power Cable <b>IN BAG</b>	1		1501489
3/4" BSPM x 3/8" Pushfit	1		1400823
3/8" [Y] x 2-Way Divider	1		1400814
3/8" x 3/8" elbow	1		1400772
Fixing bracket	2		n/a

MARCO is an  
ISO9001:2000  
Registered  
Company.

