NO. L009-872

ISSUED: JUN. 1, 2012

REVISED: JUN. 14, 2013



**HOSHIZAKI
CUBELET ICE DISPENSER**

**MODEL DCM-60KE
 DCM-60KE-P
 DCM-120KE
 DCM-120KE-P**

SERVICE MANUAL

CONTENTS

PAGE

I. SPECIFICATIONS -----	1
1. DIMENSIONS/SPECIFICATIONS -----	1
[a] DCM-60KE (L013: Continental) -----	1
[b] DCM-60KE (L013-C101: UK) -----	2
[c] DCM-60KE (L013-C201: Oceania) -----	3
[d] DCM-60KE (L013-C301: China)-----	4
[e] DCM-60KE (L013-C130: Middle East)-----	5
[f] DCM-60KE-P (L014: Continental) -----	6
[g] DCM-60KE-P (L014-C101: UK) -----	7
[h] DCM-60KE-P (L014-C201: Oceania) -----	8
[i] DCM-60KE-P (L014-C301: China)-----	9
[j] DCM-60KE-P (L014-C130: Middle East)-----	10
[k] DCM-120KE (L009: Continental) -----	11
[l] DCM-120KE (L009-C101: UK)-----	12
[m] DCM-120KE (L009-C201: Oceania)-----	13
[n] DCM-120KE (L009-C301: China) -----	14
[o] DCM-120KE-P (L010: Continental)-----	15
[p] DCM-120KE-P (L010-C101: UK)-----	16
[q] DCM-120KE-P (L010-C201: Oceania)-----	17
[r] DCM-120KE-P (L010-C301: China)-----	18
2. CONSTRUCTION -----	19
II. MAINTENANCE AND CLEANING INSTRUCTIONS -----	21
1. EXTRUDING HEAD (UPPER BEARING), HOUSING (LOWER BEARING) -----	21
2. MECHANICAL SEAL -----	21
3. GEAR MOTOR -----	22
4. CONDENSER -----	22
5. AIR FILTER -----	22
6. CONTROL WATER VALVE AND WATER DISPENSE VALVE -----	23
7. CLEANING OF WATER SYSTEM -----	24
III. TECHNICAL INFORMATION-----	27
1. WATER CIRCUIT AND REFRIGERANT CIRCUIT -----	27
2. WIRING DIAGRAM -----	28
3. ICEMAKING MECHANISM -----	29
[a] EVAPORATOR (CASING)-----	30
[b] AUGER -----	30
[c] EXTRUDING HEAD (BEARING)-----	30
[d] HOUSING-----	30
[e] MECHANICAL SEAL -----	30
[f] COUPLING (SPLINE JOINT) -----	30
[g] GEAR MOTOR -----	30
[h] SEALING BOLT -----	31
4. ELECTRIC CIRCUIT -----	32
[a] BASIC OPERATION -----	32
[b] TIMING CHART -----	33

5. OPERATION BOARD -----	34
[a] DISPLAYING COMPRESSOR OPERATING HOURS -----	34
[b] DISPLAYING CYCLE TIME -----	34
[c] DISPLAYING MODEL NUMBER -----	35
[d] SETTING MODEL NUMBER -----	35
[e] DISPLAYING CONTROLLER BOARD SOFTWARE VERSION -----	36
[f] DISPLAYING OPERATION BOARD SOFTWARE VERSION -----	36
[g] DISPLAYING ERROR LOG AND ONGOING ERROR -----	36
[h] RESETTING ERROR LOG -----	37
[i] REDUCING COMPRESSOR STARTING TIME -----	37
[j] RESETTING COMPRESSOR OPERATING HOURS -----	37
6. ERROR CODES -----	38
7. PERFORMANCE DATA -----	41
[a] DCM-60KE(-P): 50Hz -----	41
[b] DCM-60KE(-P): 60Hz -----	42
[c] DCM-120KE(-P): 50Hz -----	43
[d] DCM-120KE(-P): 60Hz -----	44
8. ICE DISPENSING CAPACITY -----	45
[a] DCM-60KE(-P): 50/60Hz [AT: 21°C, WT: 15°C] -----	45
[b] DCM-60KE(-P): 50/60Hz [AT: 32°C, WT: 21°C] -----	46
[c] DCM-120KE(-P): 50/60Hz [AT: 21°C, WT: 15°C] -----	47
[d] DCM-120KE(-P): 50/60Hz [AT: 32°C, WT: 21°C] -----	48
 IV. SERVICE DIAGNOSIS -----	 49
1. NO ICE PRODUCTION -----	49
2. LOW ICE PRODUCTION -----	51
3. FAULTY DISPENSER -----	51
4. OTHERS -----	52
 V. REMOVAL AND REPLACEMENT -----	 53
1. FRONT COVER -----	53
[a] REMOVAL -----	53
[b] REPLACEMENT -----	55
2. SERVICE FOR REFRIGERANT LINES -----	56
[a] SERVICE INFORMATION -----	56
[b] REFRIGERANT RECOVERY -----	57
[c] EVACUATION AND RECHARGE -----	57
3. BRAZING -----	58
4. COMPRESSOR -----	58
5. DRIER -----	59
6. EXPANSION VALVE -----	60
7. FAN MOTOR -----	61
8. EVAPORATOR ASSEMBLY -----	61
9. CONTROL WATER VALVE AND WATER DISPENSE VALVE -----	63
10. FLUSH WATER VALVE -----	64
11. CONTROLLER BOARD -----	65
[a] MODIFICATION -----	65
[b] REPLACEMENT -----	65
12. BIN CONTROL SWITCH ASSEMBLY -----	66
13. STORAGE BIN ASSEMBLY -----	67
14. AGITATOR AND DRIP RING -----	67

I. SPECIFICATIONS

1. DIMENSIONS/SPECIFICATIONS

[a] DCM-60KE (L013: Continental)

ITEM	HOSHIZAKI CHIP ICE DISPENSER
MODEL	DCM-60KE
POWER SUPPLY	1 Phase 220 - 240V 50Hz Capacity: 0.60kVA (2.6A)
AMPERAGE	1.5A Starting: 9.5A
ELECTRIC CONSUMPTION	280W (Power Factor: 81%)
ICE PRODUCTION PER 24H	Approx. 63kg (Ambient Temp. 10c; Water Temp. 10c)
	Approx. 50kg (Ambient Temp. 21c; Water Temp. 15c)
	Approx. 38kg (Ambient Temp. 32c; Water Temp. 21c)
SHAPE OF ICE	Cubelet:(Compressed Flake Ice)
STORAGE CAPACITY	Approx. 1.9kg
	Approx. 78cups/30min (Ambient Temp. 10c; Water Temp. 10c)
	Approx. 110cups/1hour (Ambient Temp. 10c; Water Temp. 10c)
	Approx. 73cups/30min (Ambient Temp. 21c; Water Temp. 15c)
	Approx. 99cups/1hour (Ambient Temp. 21c; Water Temp. 15c)
	Approx. 67cups/30min (Ambient Temp. 32c; Water Temp. 21c)
	Approx. 87cups/1hour (Ambient Temp. 32c; Water Temp. 21c)
WATER CONSUMPTION PER 24H	Approx. 0.060m ³ (Ambient Temp. 10c; Water Temp. 10c)
	Approx. 0.050m ³ (Ambient Temp. 21c; Water Temp. 15c)
	Approx. 0.038m ³ (Ambient Temp. 32c; Water Temp. 21c)
OUTSIDE DIMENSIONS	350mm(W)x 585mm(D)x 695mm(H)
INSULATION FOAM	HFC-245fa, 365mfc
BLOWING AGENT	460W (Ambient Temp. 32c; Water Temp. 21c)
HEAT REJECTION	Stainless Steel(Side, Rear)
EXTERIOR	ABS Molding(Front, Top, Drain Pan)
ICE MAKING SYSTEM	Thin ice forming inside Cylinder
CONNECTING-ELECTRIC	Y-Type Connection (with CONT. Plug)
CONNECTING-WATER SUPPLY	Direct Connection to Water Main, Inlet G3/4(Bottom)
CONNECTING-DRAIN	Drain Hose, I.D.φ25mm(Bottom)
HARVESTING SYSTEM	Direct driven Auger
ICE DISPENSING SYSTEM	Push Lever and Solenoid (with Select Switch) Portion control by Dispense Switch
WATER DISPENSING SYSTEM	Push Lever and Water Valve (with Select Switch)
COMPRESSOR	Hermetic
CONDENSER	Fin and Tube type, Air-cooled
EVAPORATOR	Tube coiled around Cylinder (Solder Plated)
REFRIGERANT	R134a
BIN CONTROL	Mechanical Bin Control (Time Delay Controlled)
ICE MAKING WATER CONTROL	Float Switch and Water Valve
ELECTRICAL CIRCUIT PROTECTION	TOA Circuit Breaker
REFRIGERANT CIRCUIT PROTECTION	Compressor Internal Thermostat Condensing Temperature detected by Thermistor(Auto-reset)
INTERLOCK	Shutdown by Microprocessor (Manual-reset)
WEIGHT	Net: 47kg(Gross: 56kg)
PACKAGE	Carton 440mm(W)x 655mm(D)x 931mm(H)
ACCESSORIES	Installation Kit, Brush
OPERATING CONDITION	Ambient Temp.: 5-40° C, Water Supply Temp.: 5-35c Water Supply Pressure: 0.05-0.78MPa Voltage Range: Rated Voltage±6%

*We reserve the right to make changes in specifications and design without prior notice.

1. Install the ice maker properly in accordance with the instructions on location, water supply/drain connections and electrical connections stated in the instruction and installation manuals provided.
2. The ice production depends on the ambient and water temperatures. Refer to the instruction manual.
3. The amperage and electric consumption are based on measurements with the ice dispensing solenoid off.
4. Product Code: L013

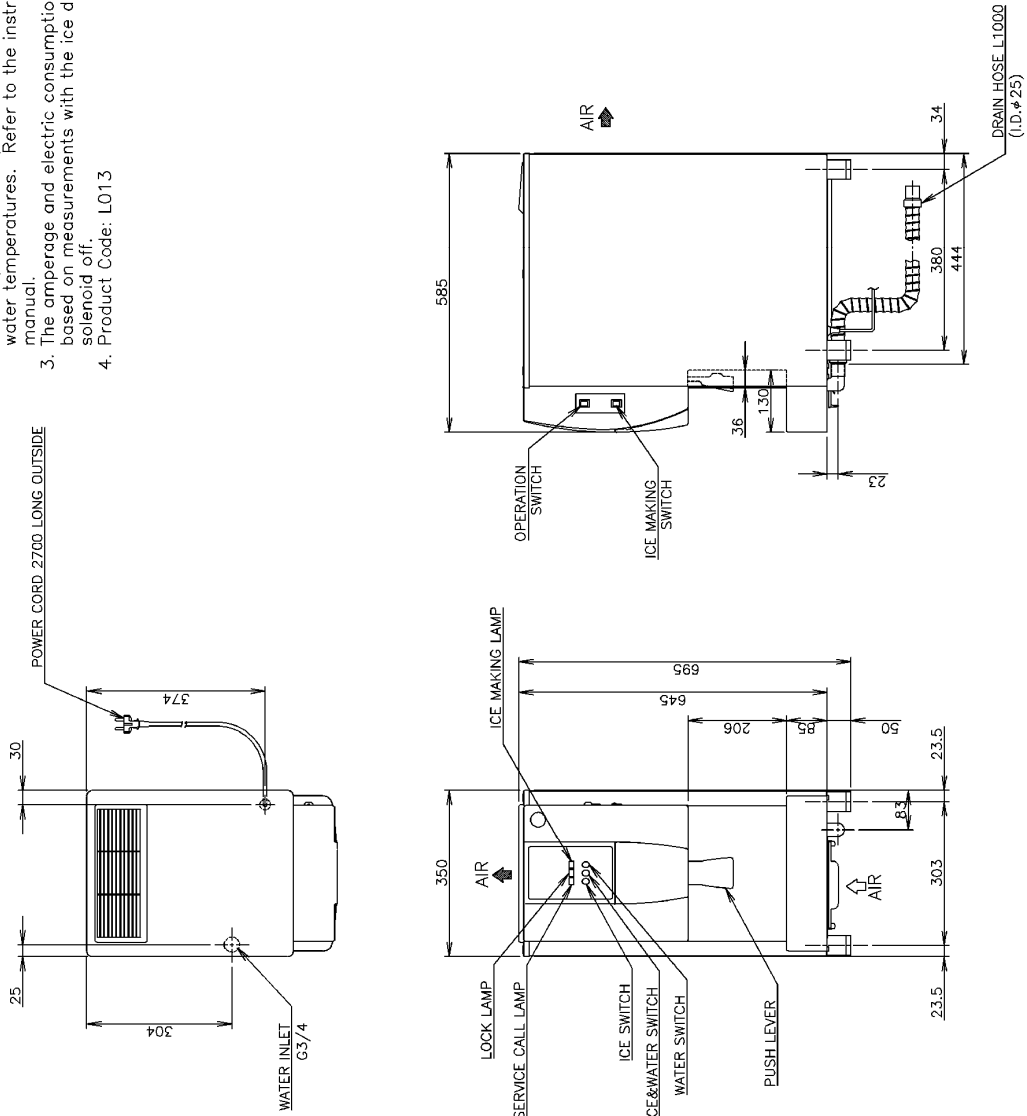

[b] DCM-60KE (L013-C101: UK)

1. Install the ice maker properly in accordance with the instructions on location, water supply/drain connections and electrical connections stated in the instruction and installation manuals provided.
2. The ice production depends on the ambient and water temperatures. Refer to the instruction manual.
3. The amperage and electric consumption are based on measurements with the ice dispensing solenoid off.
4. Product Code: L013-C101

ITEM	HOSHIZAKI CHIP ICE DISPENSER
MODEL	DCM-60KE
POWER SUPPLY	1 Phase 220 – 240V 50Hz Capacity: 0.60kVA (2.6A)
AMPERAGE	1.5A Starting: 9.5A
ELECTRIC CONSUMPTION	280W (Power Factor: 81%)
ICE PRODUCTION (PER 24H)	Approx. 60kg (Ambient Temp. 10°C, Water Temp. 10°C) Approx. 50kg (Ambient Temp. 21°C, Water Temp. 15°C) Approx. 39kg (Ambient Temp. 32°C, Water Temp. 21°C)
SHAPE OF ICE	Cubeliet(Compressed Flake Ice)
STORAGE CAPACITY	Approx. 1.9kg
ICE DISPENSING RATE (40g/CUP)	Approx. 78cups/30min (Ambient Temp. 10°C, Water Temp. 10°C)
	Approx. 110cups/1hour (Ambient Temp. 10°C, Water Temp. 10°C)
	Approx. 73cups/30min (Ambient Temp. 21°C, Water Temp. 15°C)
	Approx. 99cups/1hour (Ambient Temp. 21°C, Water Temp. 15°C)
WATER CONSUMPTION (PER 24H)	Approx. 67cups/30min (Ambient Temp. 32°C, Water Temp. 21°C)
	Approx. 87cups/1hour (Ambient Temp. 32°C, Water Temp. 21°C)
OUTSIDE DIMENSIONS	Approx. 0.060m ³ (Ambient Temp. 10°C, Water Temp. 10°C) Approx. 0.050m ³ (Ambient Temp. 21°C, Water Temp. 15°C) Approx. 0.038m ³ (Ambient Temp. 32°C, Water Temp. 21°C)
INSULATION FOAM BLOWING AGENT	350mm(W)×585mm(D)×695(~710)mm(H)
HEAT REJECTION	HFC-245fa, 365mfc
EXTERIOR	460W (Ambient Temp. 32°C, Water Temp. 21°C) Stainless Steel(Side, Rear) ABS Molding(Front, Top, Drain Pan)
ICE MAKING SYSTEM	Thin ice forming inside Cylinder
CONNECTIONS-ELECTRIC	Y-Type Connection (with UK Plug)
CONNECTIONS-WATER SUPPLY	Direct Connection to Water Main, Inlet G3/4(Bottom)
CONNECTIONS-DRAIN	Drain Hose, I.D. φ 25mm(Bottom)
HARVESTING SYSTEM	Direct driven Auger
ICE DISPENSING SYSTEM	Push Lever and Solenoid (with Select Switch) Portion control by Dispense Switch
WATER DISPENSING SYSTEM	Push Lever and Water Valve (with Select Switch)
COMPRESSOR	Hermetic
CONDENSER	Fin and Tube type, Air-cooled
EVAPORATOR	Tube coiled around Cylinder (Solder Plated)
REFRIGERANT	R134a
BIN CONTROL	Mechanical Bin Control (Time Delay Controlled)
ICE MAKING WATER CONTROL	Float Switch and Water Valve
ELECTRICAL CIRCUIT PROTECTION	10A Circuit Breaker
REFRIGERANT CIRCUIT PROTECTION	Compressor Internal Thermostat Condensing Temperature detected by Thermistor(Auto-reset)
INTERLOCK	Shutdown by Microprocessor (Manual-reset)
WEIGHT	Net: 47kg(Gross: 56kg)
PACKAGE	Carton 440mm(W)×655mm(D)×931mm(H)
ACCESSORIES	Installation Kit, Brush
OPERATING CONDITION	Ambient Temp.: 5-40° C, Water Supply Temp.: 5-35°C Water Supply Pressure: 0.05-0.78MPa Voltage Range: Rated Voltage±6%

*We reserve the right to make changes in specifications and design without prior notice.

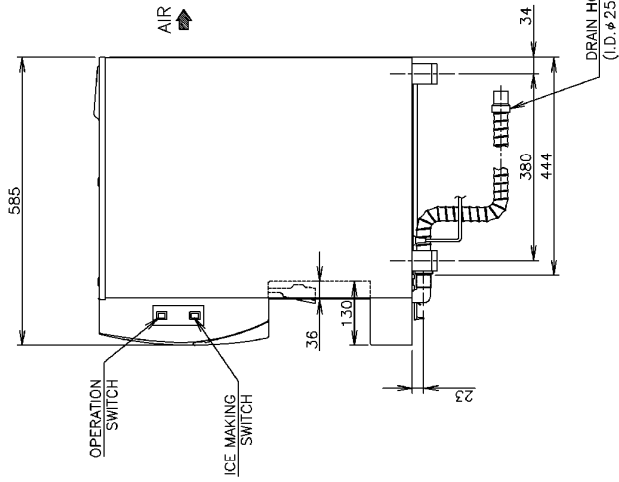
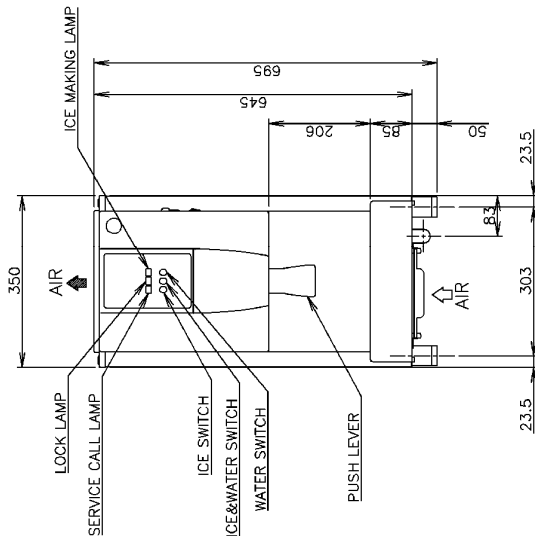
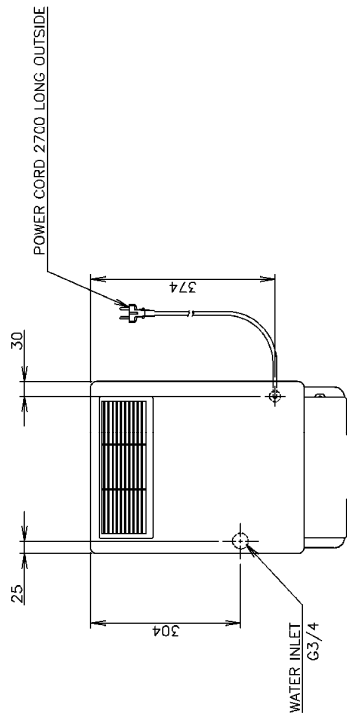

[c] DCM-60KE (L013-C201: Oceania)

1. Install the ice maker properly in accordance with the instructions on location, water supply/drain connections and electrical connections stated in the instruction and installation manuals provided.
2. The ice production depends on the ambient and water temperatures. Refer to the instruction manual.
3. The amperage and electric consumption are based on measurements with the ice dispensing solenoid off.
4. Product Code: L013-C201

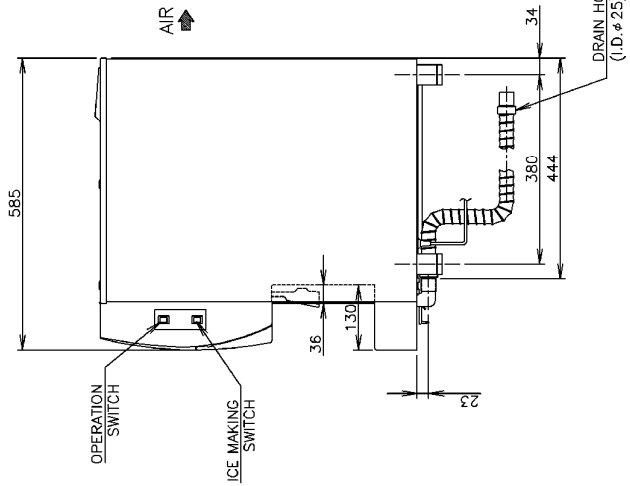
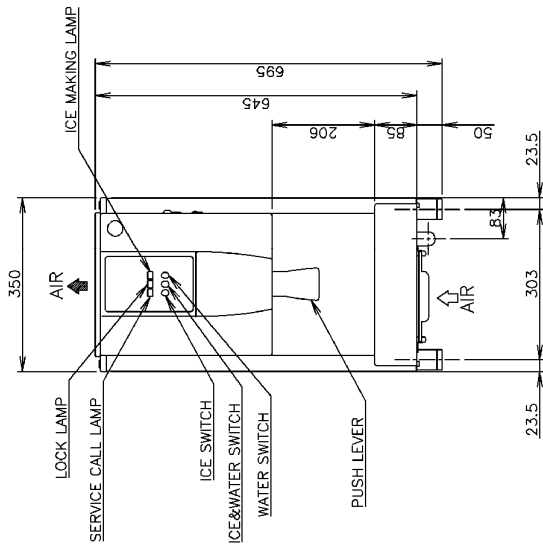
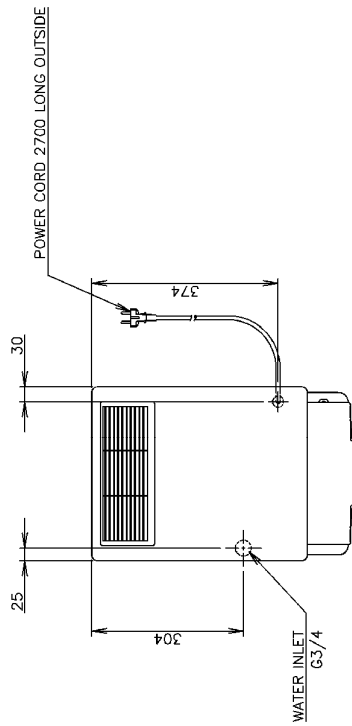

ITEM	HOSHIZAKI CHIP ICE DISPENSER
MODEL	DCM-60KE
POWER SUPPLY	1 Phase 220 - 240V 50Hz Capacity: 0.60kVA (2.6A)
AMPERAGE	1.5A Starting: 9.5A
ELECTRIC CONSUMPTION	280W (Power Factor: 81%)
ICE PRODUCTION PER 24H	Approx. 60kg (Ambient Temp. 10C, Water Temp. 10C) Approx. 50kg (Ambient Temp. 21C, Water Temp. 15C) Approx. 38kg (Ambient Temp. 32C, Water Temp. 21C)
SHAPE OF ICE	Cubelet(Compressed Flake Ice)
STORAGE CAPACITY	Approx. 1.9kg Approx. 78cups/30min (Ambient Temp. 10C, Water Temp. 10C) Approx. 110cups/hour (Ambient Temp. 10C, Water Temp. 10C) Approx. 73cups/30min (Ambient Temp. 21C, Water Temp. 15C) Approx. 99cups/hour (Ambient Temp. 21C, Water Temp. 15C) Approx. 67cups/30min (Ambient Temp. 32C, Water Temp. 21C) Approx. 87cups/hour (Ambient Temp. 32C, Water Temp. 21C)
ICE DISPENSING RATE (40g/CUP)	Approx. 0.060m ³ /hour (Ambient Temp. 10C, Water Temp. 10C) Approx. 0.050m ³ /hour (Ambient Temp. 21C, Water Temp. 15C) Approx. 0.036m ³ /hour (Ambient Temp. 32C, Water Temp. 21C)
WATER CONSUMPTION PER 24H	Approx. 0.060m ³ /hour (Ambient Temp. 10C, Water Temp. 10C) Approx. 0.050m ³ /hour (Ambient Temp. 21C, Water Temp. 15C) Approx. 0.036m ³ /hour (Ambient Temp. 32C, Water Temp. 21C)
OUTSIDE DIMENSIONS	350mm(W)×585mm(D)×695(~710)mm(H)
INSULATION FOAM BLOWING AGENT	HFC-245fa, 365mfc
HEAT REJECTION	460W (Ambient Temp. 32C, Water Temp. 21C)
EXTERIOR	Stainless Steel(Side, Rear) ABS Molding(Front, Top, Drain Pan)
ICE MAKING SYSTEM	Thin ice forming inside Cylinder
CONNECTIONS-ELECTRIC	Y-Type Connection (with OCEANIA, Plug)
CONNECTING-WATER SUPPLY	Direct Connection to Water Main, Inlet G3/4(Bottom)
CONNECTIONS-DRAIN	Drain Hose, I.D. φ 25mm(Bottom)
HARVESTING SYSTEM	Direct driven Auger
ICE DISPENSING SYSTEM	Push Lever and Solenoid (with Select Switch) Portion control by Dispense Switch
WATER DISPENSING SYSTEM	Push Lever and Water Valve (with Select Switch)
COMPRESSOR	Hermetic
CONDENSER	Fin and Tube type, Air-cooled
EVAPORATOR	Tube coiled around Cylinder (Solder Plated)
REFRIGERANT	R134a
BIN CONTROL	Mechanical Bin Control (Time Delay Controlled)
ICE MAKING WATER CONTROL	Float Switch and Water Valve
ELECTRICAL CIRCUIT PROTECTION	10A Circuit Breaker
REFRIGERANT CIRCUIT PROTECTION	Compressor Internal Thermostat Condensing Temperature detected by Thermistor(Auto-reset)
INTERLOCK	Shutdown by Microprocessor (Manual-reset)
WEIGHT	Net: 47kg(Gross: 56kg)
PACKAGE	Carton 440mm(W)×655mm(D)×931mm(H)
ACCESSORIES	Installation Kit, Brush
OPERATING CONDITION	Ambient Temp.: 5-40° C, Water Supply Temp.: 5-35C Water Supply Pressure: 0.05-0.78MPa Voltage Range: Rated Voltage±6%

*We reserve the right to make changes in specifications and design without prior notice.

[d] DCM-60KE (L013-C301: China)

1. Install the ice maker properly in accordance with the instructions on location, water supply/drain connections and electrical connections stated in the instruction and installation manuals provided.
2. The ice production depends on the ambient and water temperatures. Refer to the instruction manual.
3. The amperage and electric consumption are based on measurements with the ice dispensing solenoid off.
4. Product Code: L013-C301

ITEM	HOSHIZAKI CHIP ICE DISPENSER
MODEL	DCM-60KE
POWER SUPPLY	1 Phase 220 - 240V 50Hz Capacity: 0.60kVA (2.6A)
AMPERAGE	1.5A Starting: 9.5A
ELECTRIC CONSUMPTION	280W (Power Factor: 81%)
ICE PRODUCTION PER 24H	Approx. 60kg (Ambient Temp. 10c, Water Temp. 10c) Approx. 50kg (Ambient Temp. 21c, Water Temp. 15c) Approx. 38kg (Ambient Temp. 32c, Water Temp. 21c)
SHAPE OF ICE	Cubelet (Compressed Flake Ice)
STORAGE CAPACITY	Approx. 1.9kg
ICE DISPENSING RATE (40g/CUP)	Approx. 78cups/30min (Ambient Temp. 10c, Water Temp. 10c) Approx. 110cups/1hour (Ambient Temp. 10c, Water Temp. 10c) Approx. 73cups/30min (Ambient Temp. 21c, Water Temp. 15c) Approx. 99cups/1hour (Ambient Temp. 21c, Water Temp. 15c) Approx. 67cups/30min (Ambient Temp. 32c, Water Temp. 21c) Approx. 87cups/1hour (Ambient Temp. 32c, Water Temp. 21c)
WATER CONSUMPTION PER 24H	Approx. 0.060m ³ (Ambient Temp. 10c, Water Temp. 10c) Approx. 0.050m ³ (Ambient Temp. 21c, Water Temp. 15c) Approx. 0.038m ³ (Ambient Temp. 32c, Water Temp. 21c)
OUTSIDE DIMENSIONS	350mm(W) x 585mm(D) x 695 (~710)mm(H)
INSULATION FOAM BLOWING AGENT	HFC - 245fa, 365mfc
HEAT REJECTION	460W (Ambient Temp. 32c, Water Temp. 21c)
EXTERIOR	Stainless Steel (Side, Rear) ABS Molding (Front, Top, Drain Pan)
ICE MAKING SYSTEM	Thin ice forming inside Cylinder
CONNECTIONS-ELECTRIC	Y-Type Connection (with CHINA, Plug)
CONNECTIONS-WATER SUPPLY	Direct Connection to Water Main, Inlet G3/4 (Bottom)
CONNECTIONS-DRAIN	Drain Hose, I.D. φ 25mm (Bottom)
HARVESTING SYSTEM	Direct driven Auger
ICE DISPENSING SYSTEM	Push Lever and Solenoid (with Select Switch) Portion control by Dispense Switch
WATER DISPENSING SYSTEM	Push Lever and Water Valve (with Select Switch)
COMPRESSOR	Hermetic
CONDENSER	Fin and Tube type, Air-cooled
EVAPORATOR	Tube coiled around Cylinder (Solder Plated)
REFRIGERANT	R134a
BIN CONTROL	Mechanical Bin Control (Time Delay Controlled)
ICE MAKING WATER CONTROL	Float Switch and Water Valve
ELECTRICAL CIRCUIT PROTECTION	10A Circuit Breaker
REFRIGERANT CIRCUIT PROTECTION	Compressor Internal Thermostat
INTERLOCK	Condensing Temperature detected by Thermistor (Auto-reset) Shutdown by Microprocessor (Manual-reset)
WEIGHT	Net: 47kg (Gross: 56kg)
PACKAGE	Carton 440mm(W) x 655mm(D) x 931mm(H)
ACCESSORIES	Installation Kit, Brush
OPERATING CONDITION	Ambient Temp.: 5-40° C, Water Supply Temp.: 5-35c Water Supply Pressure: 0.05-0.78MPa Voltage Range: Rated Voltage ± 6%

*We reserve the right to make changes in specifications and design without prior notice.

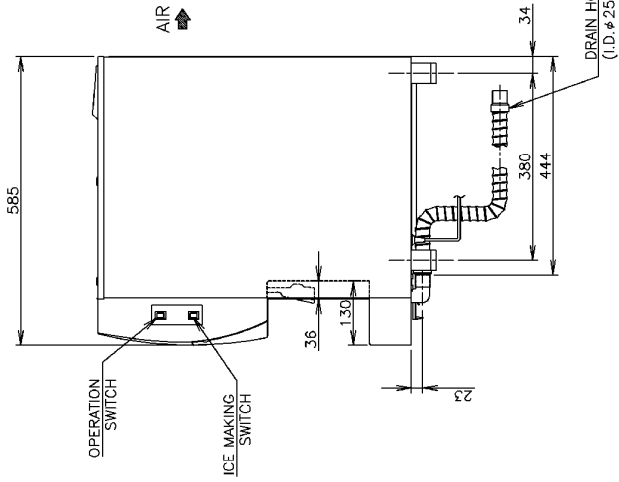
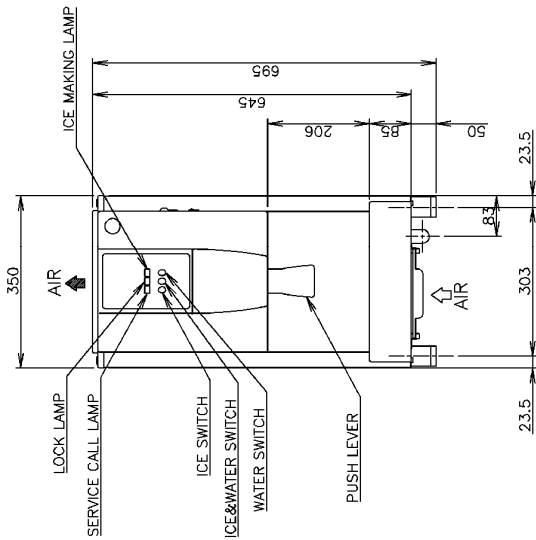
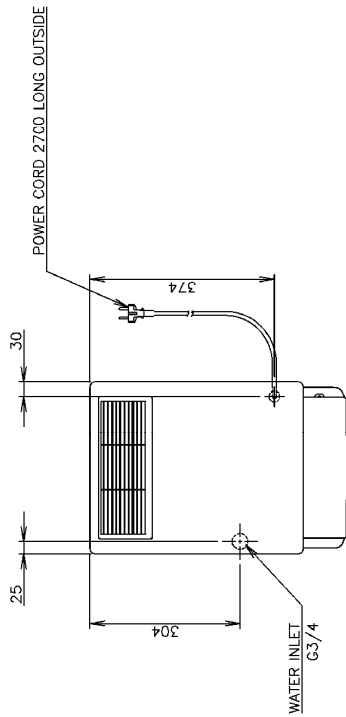

[e] DCM-60KE (L013-C130: Middle East)

1. Install the ice maker properly in accordance with the instructions on location, water supply/drain connections and electrical connections stated in the instruction and installation manuals provided.
2. The ice production depends on the ambient and water temperatures. Refer to the instruction manual.
3. The amperage and electric consumption are based on measurements with the ice dispensing solenoid off.
4. Product Code: L013-C130

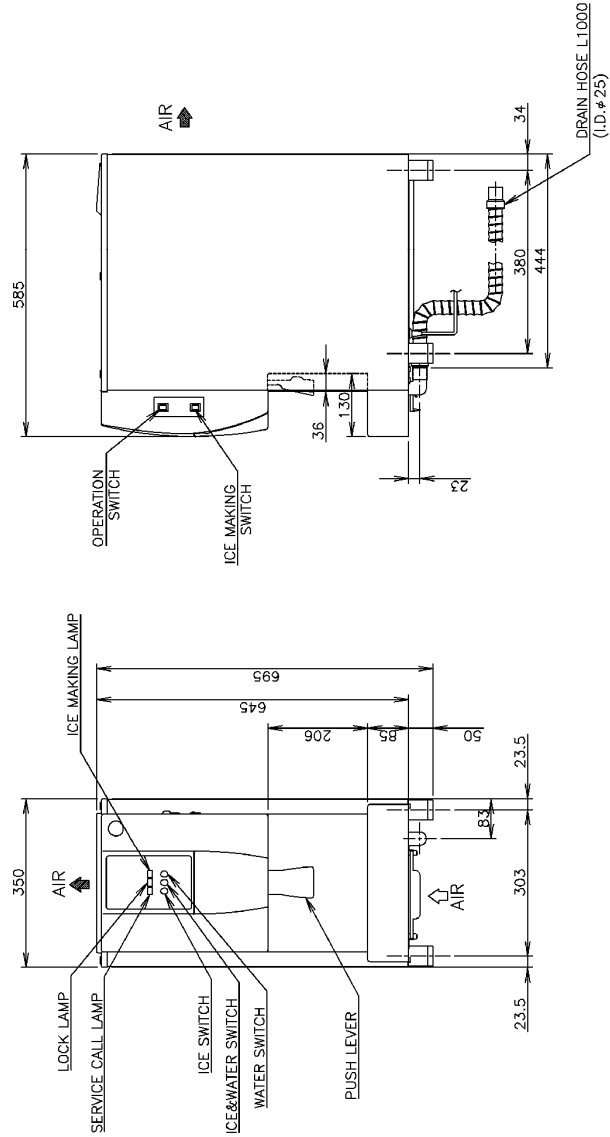
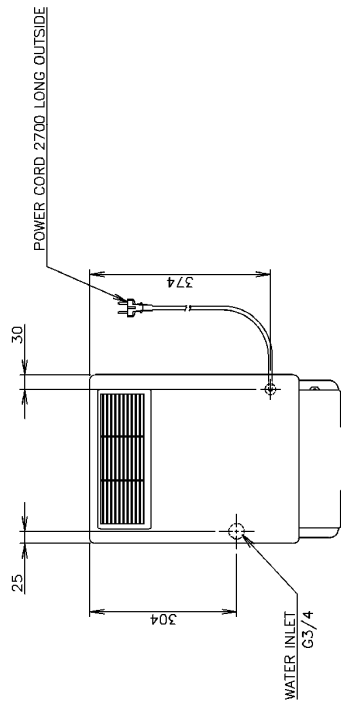

ITEM	HOSHIZAKI CHIP ICE DISPENSER
MODEL	DCM-60KE
POWER SUPPLY	1 Phase 220 - 230V 60Hz Capacity: 0.45kVA (2.0A)
AMPERAGE	1.5A Starting: 5.7A
ELECTRIC CONSUMPTION	320W (Power Factor: 92%)
ICE PRODUCTION PER 24h	Approx. 60kg (Ambient Temp. 10C, Water Temp. 10C) Approx. 50kg (Ambient Temp. 21C, Water Temp. 15C) Approx. 35kg (Ambient Temp. 32C, Water Temp. 21C)
SHAPE OF ICE	Cubelet (Compressed Flake Ice)
STORAGE CAPACITY	Approx. 1.9kg
ICE DISPENSING RATE (14kg/CUP)	Approx. 78cups/30min (Ambient Temp. 10C, Water Temp. 10C)
	Approx. 110cups/1hour (Ambient Temp. 10C, Water Temp. 10C)
	Approx. 73cups/30min (Ambient Temp. 21C, Water Temp. 15C)
	Approx. 98cups/1hour (Ambient Temp. 21C, Water Temp. 15C)
WATER CONSUMPTION PER 24h	Approx. 67cups/30min (Ambient Temp. 32C, Water Temp. 21C)
	Approx. 87cups/1hour (Ambient Temp. 32C, Water Temp. 21C)
OUTSIDE DIMENSIONS	Approx. 0.060m ³ (Ambient Temp. 10C, Water Temp. 10C)
	Approx. 0.050m ³ (Ambient Temp. 21C, Water Temp. 15C)
	Approx. 0.038m ³ (Ambient Temp. 32C, Water Temp. 21C)
INSULATION FOAM BLOWING AGENT	350mm(W)×585mm(D)×695(~710)mm(H)
HEAT REJECTION	HFC-245fa, 365mfc
EXTERIOR	450W (Ambient Temp. 32C, Water Temp. 21C) Stainless Steel (Side, Rear) ABS Molding (Front, Top, Drain Pan)
ICE MAKING SYSTEM	Thin ice forming inside Cylinder
CONNECTING-ELECTRIC	Y-Type Connection (with UK Plug)
CONDENSING-WATER SUPPLY	Direct Connection to Water Main, Inlet G3/4 (Bottom)
CONNECTIONS-DRAIN	Drain Hose, I.D. φ25mm (Bottom)
HARVESTING SYSTEM	Direct driven Auger
ICE DISPENSING SYSTEM	Push Lever and Solenoid (with Select Switch) Portion control by Dispense Switch
WATER DISPENSING SYSTEM	Push Lever and Water Valve (with Select Switch)
COMPRESSOR	Hermetic
CONDENSER	Fin and Tube type, Air-cooled
EVAPORATOR	Tube coiled around Cylinder (Solder Plated)
REFRIGERANT	R134a
BIN CONTROL	Mechanical Bin Control (Time Delay Controlled)
ICE MAKING WATER CONTROL	Float Switch and Water Valve
ELECTRICAL CIRCUIT PROTECTION	10A Circuit Breaker Compressor Internal Thermostat Condensing Temperature detected by Thermistor (Auto-reset)
INTERLOCK	Shutdown by Microprocessor (Manual--reset)
WEIGHT	Net: 47kg (Gross: 56kg)
PACKAGE	Carton 440mm(W)×655mm(D)×931mm(H)
ACCESSORIES	Installation Kit, Brush Ambient Temp.: 5-40° C, Water Supply Temp.: 5-35C Water Supply Pressure: 0.05-0.78MPa Voltage Range: Rated Voltage±6%
OPERATING CONDITION	

*We reserve the right to make changes in specifications and design without prior notice.

[f] DCM-60KE-P (L014: Continental)

1. Install the ice maker properly in accordance with the instructions on location, water supply/drain connections and electrical connections stated in the instruction and installation manuals provided.
2. The ice production depends on the ambient and water temperatures. Refer to the instruction manual.
3. The amperage and electric consumption are based on measurements with the ice dispensing solenoid off.
4. Product Code: L014

ITEM	HOSHIZAKI CHIP ICE DISPENSER
MODEL	DCM-60KE-P
POWER SUPPLY	1 Phase 220 - 240V 50Hz Capacity: 0.60kVA (2.8A)
AMPERAGE	1.5A Starting: 9.5A
ELECTRIC CONSUMPTION	280W (Power Factor: 81%)
ICE PRODUCTION PER 24H	Approx. 60kg (Ambient Temp. 10°C, Water Temp. 10°C) Approx. 50kg (Ambient Temp. 21°C, Water Temp. 15°C) Approx. 33kg (Ambient Temp. 32°C, Water Temp. 21°C)
SHAPE OF ICE	Cubelet(Compressed Flake Ice)
STORAGE CAPACITY	Approx. 1.9kg
ICE DISPENSING RATE (40g/CUP)	Approx. 78cups/30min (Ambient Temp. 10°C, Water Temp. 10°C) Approx. 110cups/1hour (Ambient Temp. 10°C, Water Temp. 10°C) Approx. 73cups/30min (Ambient Temp. 21°C, Water Temp. 15°C) Approx. 98cups/1hour (Ambient Temp. 21°C, Water Temp. 15°C) Approx. 67cups/30min (Ambient Temp. 32°C, Water Temp. 21°C) Approx. 87cups/1hour (Ambient Temp. 32°C, Water Temp. 21°C)
WATER CONSUMPTION PER 24H	Approx. 0.060m ³ (Ambient Temp. 10°C, Water Temp. 10°C) Approx. 0.050m ³ (Ambient Temp. 21°C, Water Temp. 15°C) Approx. 0.038m ³ (Ambient Temp. 32°C, Water Temp. 21°C)
OUTSIDE DIMENSIONS	350mm(W) x 585mm(D) x 695mm(H)
INSULATION FOAM BLOWING AGENT	HFC-245fa, 365mfc
HEAT REJECTION	460W (Ambient Temp. 32°C, Water Temp. 21°C)
EXTERIOR	Stainless Steel(Side, Rear)
ICE MAKING SYSTEM	ABS Molding(Front, Top, Drain Pan)
CONNECTIONS-ELECTRIC	Thin ice forming inside Cylinder
CONNECTIONS-WATER SUPPLY	Y-Type Connection (with CONT. Plug)
CONNECTIONS-DRAIN	Direct Connection to Water Main, Inlet G3/4(Bottom)
HARVESTING SYSTEM	Drain Hose, I.D. φ 25mm(Bottom)
ICE DISPENSING SYSTEM	Direct driven Auger
WATER DISPENSING SYSTEM	Push Switch and Solenoid(with Select Switch) Portion control by Dispense Switch
COMPRESSOR	Push Switch and Water Valve (with Select Switch) Portion control by Dispense Switch
CONDENSER	Hermetic
EVAPORATOR	Fin and Tube type, Air-cooled
REFRIGERANT	Tube coiled around Cylinder (Solder Plated)
BIN CONTROL	R134a
ICE MAKING WATER CONTROL	Mechanical Bin Control (Time Delay Controlled)
REFRIGERANT CIRCUIT PROTECTION	10A Circuit Breaker
INTERLOCK	Compressor Internal Thermostat Condensing Temperature detected by Thermistor(Auto-reset) Shutdown by Microprocessor (Manual-reset)
WEIGHT	Net: 47kg(Gross: 56kg)
PACKAGE	Carton 440mm(W) x 655mm(D) x 931mm(H)
ACCESSORIES	Installation Kit, Brush
OPERATING CONDITION	Ambient Temp.: 5~40° C, Water Supply Temp.: 5~35°C Water Supply Pressure: 0.05~0.78MPa Voltage Range: Rated Voltage±6%

*We reserve the right to make changes in specifications and design without prior notice.

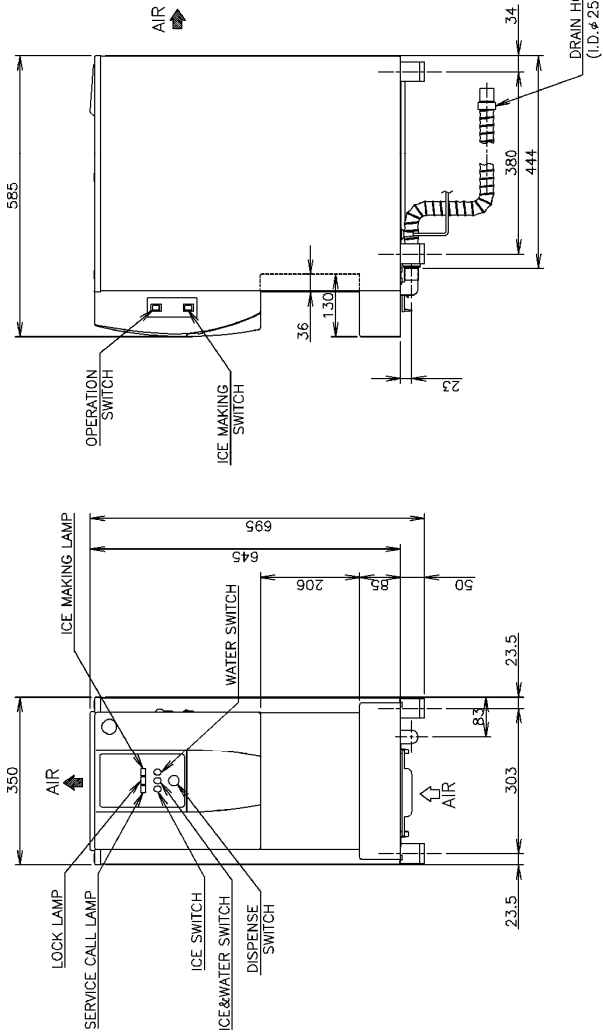
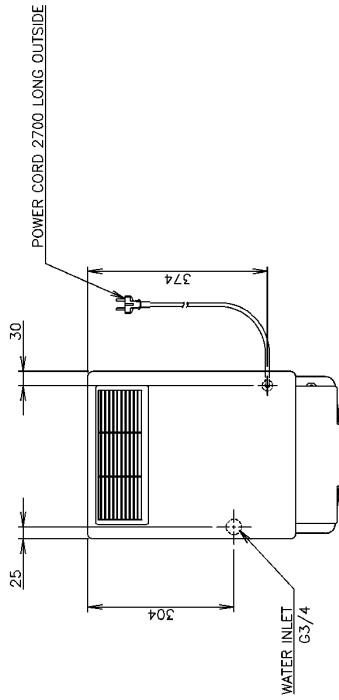

[g] DCM-60KE-P (L014-C101: UK)

1. Install the ice maker properly in accordance with the instructions on location, water supply/drain connections and electrical connections stated in the instruction and installation manuals provided.
2. The ice production depends on the ambient and water temperatures. Refer to the instruction manual.
3. The amperage and electric consumption are based on measurements with the ice dispensing solenoid off.
4. Product Code: L014-C101

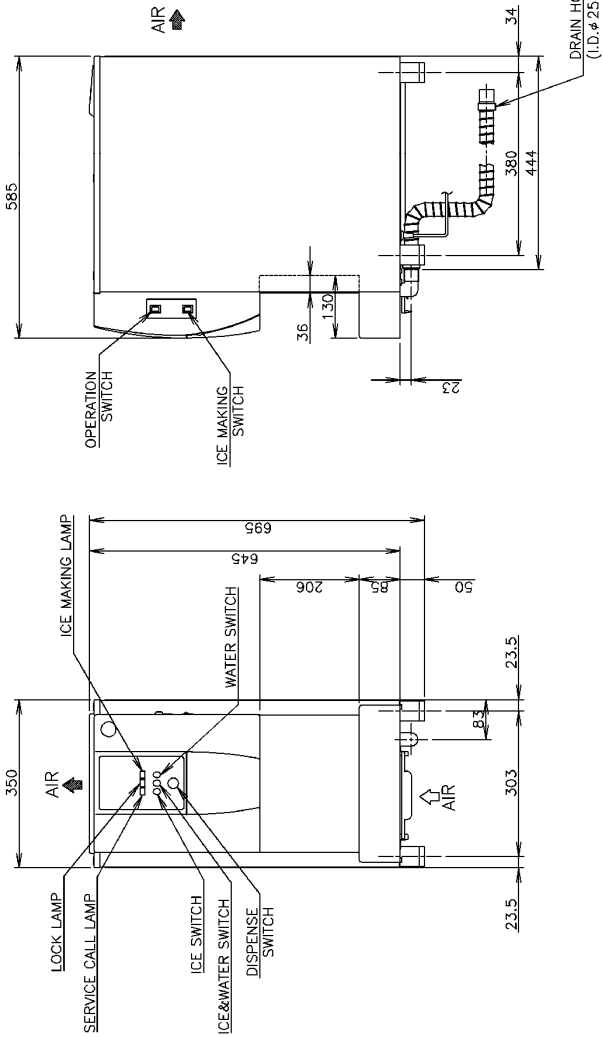
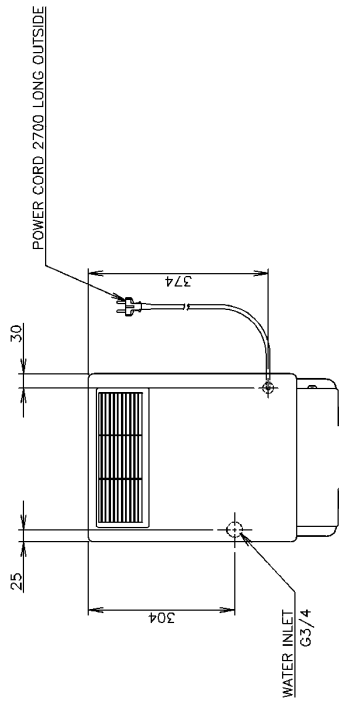

ITEM	HOSHIZAKI CHIP ICE DISPENSER
MODEL	DCM-60KE-P
POWER SUPPLY	1 Phase 220 - 240V 50Hz Capacity: 0.60kVA (2.6A)
AMPERAGE	1.5A Starting: 9.5A
ELECTRIC CONSUMPTION	280W (Power Factor: 81%)
ICE PRODUCTION PER 24h	Approx. 60kg (Ambient Temp. 10c, Water Temp. 10c)
	Approx. 50kg (Ambient Temp. 21c, Water Temp. 15c)
	Approx. 38kg (Ambient Temp. 32c, Water Temp. 21c)
SHAPE OF ICE	Cubelet (Compressed Flake Ice)
STORAGE CAPACITY	Approx. 1.9kg
	Approx. 78cups/30min (Ambient Temp. 10c, Water Temp. 10c)
	Approx. 110cups/1hour (Ambient Temp. 10c, Water Temp. 10c)
	Approx. 73cups/30min (Ambient Temp. 21c, Water Temp. 15c)
	Approx. 98cups/1hour (Ambient Temp. 21c, Water Temp. 15c)
	Approx. 67cups/30min (Ambient Temp. 32c, Water Temp. 21c)
	Approx. 87cups/1hour (Ambient Temp. 32c, Water Temp. 21c)
WATER CONSUMPTION PER 24h	Approx. 0.060m ³ (Ambient Temp. 10c, Water Temp. 10c)
	Approx. 0.050m ³ (Ambient Temp. 21c, Water Temp. 15c)
	Approx. 0.038m ³ (Ambient Temp. 32c, Water Temp. 21c)
OUTSIDE DIMENSIONS	350mm(W)x 585mm(D)x 695(~710)mm(H)
INSULATION FOAM BLOWING AGENT	HFC-245fa, 365mfc
HEAT REJECTION	460W (Ambient Temp. 32c, Water Temp. 21c)
EXTERIOR	Stainless Steel(Side, Rear)
	ABS Molding(Front, Top, Drain Pan)
ICE MAKING SYSTEM	Thin ice forming inside Cylinder
CONNECTIONS-ELECTRIC	Y-Type Connection (with UK. Plug)
CONNECTING-WATER SUPPLY	Direct Connection to Water Main, Inlet G3/4(Bottom)
CONNECTIONS-DRAIN	Drain Hose, I.D. φ 25mm(Bottom)
HARVESTING SYSTEM	Direct driven Auger
ICE DISPENSING SYSTEM	Push Switch and Solenoid(with Select Switch)
	Portion control by Dispense Switch
WATER DISPENSING SYSTEM	Push Switch and Water Valve (with Select Switch)
	Portion control by Dispense Switch
COMPRESSOR	Hermetic
CONDENSER	Fin and Tube type, Air-cooled
EVAPORATOR	Tube coiled around Cylinder (Solder Plated)
REFRIGERANT	R134a
BIN CONTROL	Mechanical Bin Control (Time Delay Controlled)
ICE MAKING WATER CONTROL	Float Switch and Water Valve
ELECTRICAL CIRCUIT PROTECTION	10A Circuit Breaker
REFRIGERANT CIRCUIT PROTECTION	Condensing Temperature detected by Thermistor(Auto-reset)
INTERLOCK	Shutdown by Microprocessor (Manual-reset)
WEIGHT	Net: 47kg(Gross: 56kg)
PACKAGE	Carton 440mm(W)x 655mm(D)x 931mm(H)
ACCESSORIES	Installation Kit, Brush
OPERATING CONDITION	Ambient Temp.: 5-40° C, Water Supply Temp.: 5-35c Water Supply Pressure: 0.05-0.78MPa Voltage Range: Rated Voltage±6%

*We reserve the right to make changes in specifications and design without prior notice.

[h] DCM-60KE-P (L014-C201: Oceania)

1. Install the ice maker properly in accordance with the instructions on location, water supply/drain connections and electrical connections stated in the instruction and installation manuals provided.
2. The ice production depends on the ambient and water temperatures. Refer to the instruction manual.
3. The amperage and electric consumption are based on measurements with the ice dispensing solenoid off.
4. Product Code: L014-C201

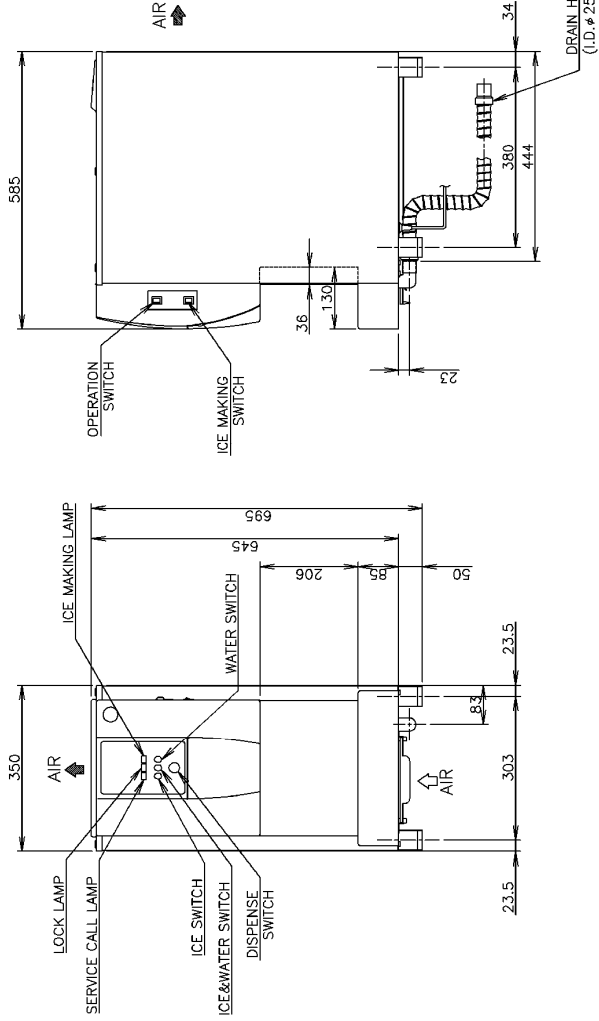
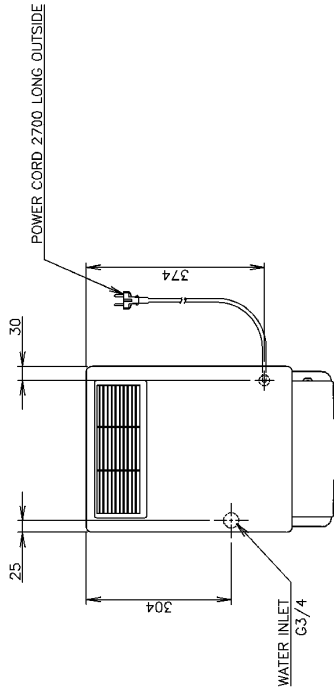

ITEM	HOSHIZAKI CHIP ICE DISPENSER
MODEL	DCM-60KE-P
POWER SUPPLY	1 Phase 220-240V 50Hz Capacity: 0.60kVA (2.6A)
AMPERAGE	1.5A Starting: 9.5A
ELECTRIC CONSUMPTION	280W (Power Factor: 81%)
ICE PRODUCTION PER 24H	Approx. 60kg (Ambient Temp. 10°C, Water Temp. 10°C) Approx. 50kg (Ambient Temp. 21°C, Water Temp. 15°C) Approx. 38kg (Ambient Temp. 32°C, Water Temp. 21°C)
SHAPE OF ICE	Cubelet (Compressed Flake Ice)
STORAGE CAPACITY	Approx. 1.9kg
ICE DISPENSING RATE (4kg/CUP)	Approx. 78cups/30min (Ambient Temp. 10°C, Water Temp. 10°C)
	Approx. 11cups/1hour (Ambient Temp. 10°C, Water Temp. 10°C)
	Approx. 73cups/30min (Ambient Temp. 21°C, Water Temp. 15°C)
WATER CONSUMPTION PER 24H	Approx. 98cups/1hour (Ambient Temp. 21°C, Water Temp. 15°C)
	Approx. 67cups/30min (Ambient Temp. 32°C, Water Temp. 21°C)
	Approx. 87cups/1hour (Ambient Temp. 32°C, Water Temp. 21°C)
OUTSIDE DIMENSIONS	Approx. 0.060m ³ (Ambient Temp. 10°C, Water Temp. 10°C)
	Approx. 0.050m ³ (Ambient Temp. 21°C, Water Temp. 15°C)
	Approx. 0.038m ³ (Ambient Temp. 32°C, Water Temp. 21°C)
INSULATION FOAM BLOWING AGENT	350mm(W)×585mm(D)×695(~710)mm(H)
HEAT REJECTION	HFC-245fa, 365mfc
EXTERIOR	460W (Ambient Temp. 32°C, Water Temp. 21°C) Stainless Steel(Side, Rear) ABS Molding(Front, Top, Drain Pan)
ICE MAKING SYSTEM	Thin ice forming inside Cylinder
CONNECTING-ELECTRIC	Y-Type Connection (with OCEANIA. Plug)
CONNECTING-WATER SUPPLY	Direct Connection to Water Main, Inlet G3/4(Bottom)
CONNECTING DRAIN	Drain Hose, I.D. φ 25mm(Bottom)
HARVESTING SYSTEM	Direct driven Auger
ICE DISPENSING SYSTEM	Push Switch and Solenoid(with Select Switch) Portion control by Dispense Switch
WATER DISPENSING SYSTEM	Push Switch and Water Valve (with Select Switch) Portion control by Dispense Switch
COMPRESSOR	Hermetic
CONDENSER	Fin and Tube type, Air-cooled
EVAPORATOR	Tube coiled around Cylinder (Solder Plated)
REFRIGERANT	R134a
BIN CONTROL	Mechanical Bin Control (Time Delay Controlled)
ICE MAKING WATER CONTROL	Float Switch and Water Valve
REGIONAL CIRCUIT PROTECTION	10A Circuit Breaker
REFRIGERANT CIRCUIT PROTECTION	Compressor Internal Thermostat Condensing Temperature detected by Thermistor(Auto-reset)
INTERLOCK	Shutdown by Microprocessor (Manual-reset)
WEIGHT	Net: 47kg(Gross: 58kg)
PACKAGE	Carton 440mm(W)×665mm(D)×931mm(H)
ACCESSORIES	Installation Kit, Brush
OPERATING CONDITION	Ambient Temp.: 5-40 °C, Water Supply Temp.: 5-35°C Water Supply Pressure: 0.05-0.78MPa Voltage Range: Rated Voltage±6%

*We reserve the right to make changes in specifications and design without prior notice.

[i] DCM-60KE-P (L014-C301: China)

1. Install the ice maker properly in accordance with the instructions on location, water supply/drain connections and electrical connections stated in the instruction and installation manuals provided.
2. The ice production depends on the ambient and water temperatures. Refer to the instruction manual.
3. The amperage and electric consumption are based on measurements with the ice dispensing solenoid off.
4. Product Code: L014-C301

ITEM	HOSHIZAKI CHIP ICE DISPENSER
MODEL	DCM-60KE-P
POWER SUPPLY	1 Phase 220 - 240V 50Hz Capacity: 0.60kVA (2.6A)
AMPERAGE	1.5A Starting: 9.5A
ELECTRIC CONSUMPTION	280W (Power Factor: 81%)
ICE PRODUCTION PER 24H	Approx. 60kg (Ambient Temp. 10°C, Water Temp. 10°C) Approx. 50kg (Ambient Temp. 21°C, Water Temp. 15°C) Approx. 38kg (Ambient Temp. 32°C, Water Temp. 21°C)
SHAPE OF ICE	Cubelet(Compressed Flake Ice)
STORAGE CAPACITY	Approx. 1.9kg Approx. 78cups/30min (Ambient Temp. 10°C, Water Temp. 10°C) Approx. 110cups/1hour (Ambient Temp. 10°C, Water Temp. 10°C) Approx. 73cups/30min (Ambient Temp. 21°C, Water Temp. 15°C) Approx. 98cups/1hour (Ambient Temp. 21°C, Water Temp. 15°C) Approx. 67cups/30min (Ambient Temp. 32°C, Water Temp. 21°C) Approx. 87cups/1hour (Ambient Temp. 32°C, Water Temp. 21°C)
WATER CONSUMPTION PER 24H	Approx. 0.060m ³ (Ambient Temp. 10°C, Water Temp. 10°C) Approx. 0.050m ³ (Ambient Temp. 21°C, Water Temp. 15°C) Approx. 0.038m ³ (Ambient Temp. 32°C, Water Temp. 21°C)
INSULATION FOAM BLOWING AGENT	350mmr(W)×585mm(D)×695(~710)mm(H)
HEAT REJECTION	HFC-245fa, 365mfc
EXTERIOR	460W (Ambient Temp. 32°C, Water Temp. 21°C) Stainless Steel(Side, Rear) ABS Welding(Front, Top, Drain Pan)
ICE MAKING SYSTEM	Thin ice forming inside Cylinder
CONNECTING-ELECTRIC	Y-Type Connection (with CHINA Plug)
CONNECTING-WATER SUPPLY	Direct Connection to Water Main, Inlet G3/4(Bottom)
CONNECTIONS-DRAIN	Drain Hose, I.D.φ25mm(Bottom)
HARVESTING SYSTEM	Direct driven Auger
ICE DISPENSING SYSTEM	Push Switch and Solenoid(with Select Switch) Portion control by Dispense Switch
WATER DISPENSING SYSTEM	Push Switch and Water Valve (with Select Switch) Portion control by Dispense Switch
COMPRESSOR	Hermetic
CONDENSER	Fan and Tube type, Air-cooled
EVAPORATOR	Tube coiled around Cylinder (Solder Plated)
REFRIGERANT	RT134a
BIN CONTROL	Mechanical Bin Control (Time Delay Controlled)
ICE MAKING WATER CONTROL	Floot Switch and Water Valve
ELECTRICAL CIRCUIT PROTECTION	10A Circuit Breaker Compressor Internal Thermostat Condensing Temperature detected by Thermistor(Auto-reset)
INTERLOCK	Shutdown by Microprocessor (Manual-reset)
WEIGHT	Net: 47kg(Gross: 56kg)
PACKAGE	Carton 440mm(W)×655mm(D)×931mm(H)
ACCESSORIES	Installation Kit, Brush
OPERATING CONDITION	Ambient Temp.: 5-40° C, Water Supply Temp.: 5-35°C Water Supply Pressure: 0.05-0.78MPa Voltage Range: Rated Voltage±6%

*We reserve the right to make changes in specifications and design without prior notice.

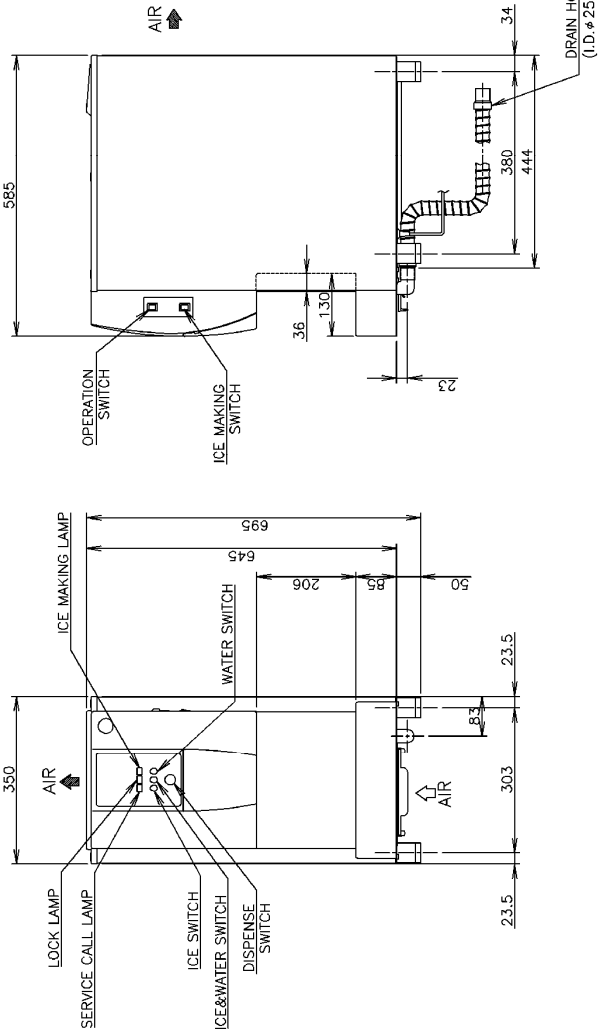
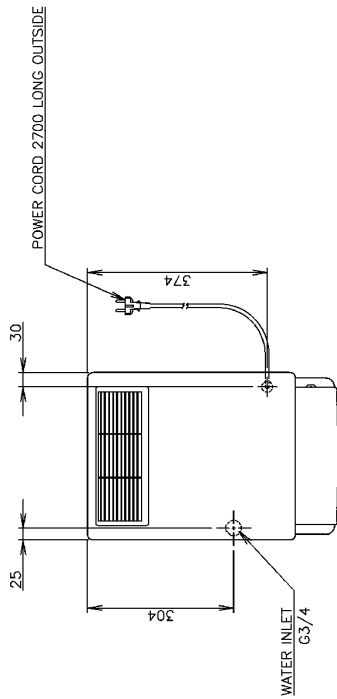

[J] DCM-60KE-P (L014-C130: Middle East)

1. Install the ice maker properly in accordance with the instructions on location, water supply/drain connections and electrical connections stated in the instruction and installation manuals provided.
2. The ice production depends on the ambient and water temperatures. Refer to the instruction manual.
3. The amperage and electric consumption are based on measurements with the ice dispensing solenoid off.
4. Product Code: L014-C130

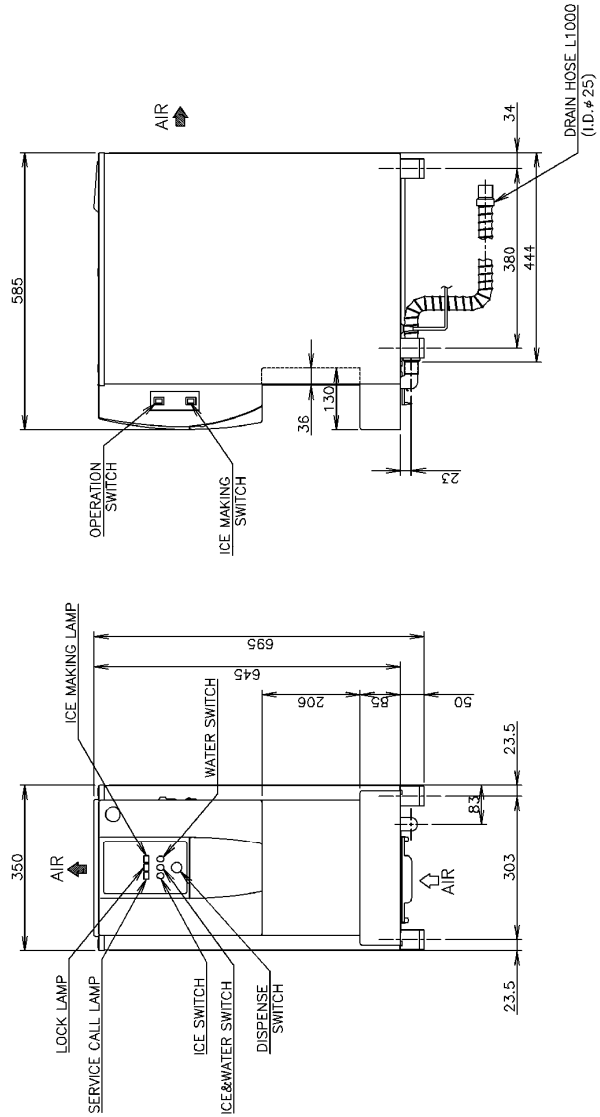
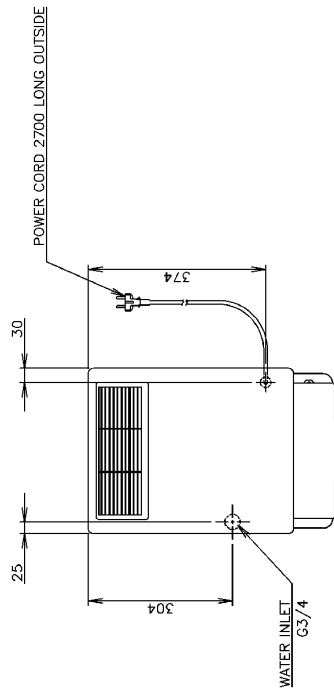

ITEM	HOSHIZAKI CHIP ICE DISPENSER
MODEL	DCM-60KE-P
POWER SUPPLY	1 Phase 220-230V 50Hz Capacity: 0.45kVA (2.0A)
AMPERAGE	1.5A Starting: 5.7A
ELECTRIC CONSUMPTION	3720W (Power Factor: 92%)
ICE PRODUCTION PER 24h	Approx. 60kg (Ambient Temp. 10c, Water Temp. 10c) Approx. 50kg (Ambient Temp. 21c, Water Temp. 15c) Approx. 38kg (Ambient Temp. 32c, Water Temp. 21c)
SHAPE OF ICE	Cubelet (Compressed Flake Ice)
STORAGE CAPACITY	Approx. 1.9kg
ICE DISPENSING RATE (40g/CUP)	Approx. 78cups/30min (Ambient Temp. 10c, Water Temp. 10c) Approx. 110cups/30min (Ambient Temp. 10c, Water Temp. 10c) Approx. 73cups/30min (Ambient Temp. 21c, Water Temp. 15c) Approx. 99cups/1hour (Ambient Temp. 21c, Water Temp. 15c) Approx. 67cups/30min (Ambient Temp. 32c, Water Temp. 21c) Approx. 87cups/1hour (Ambient Temp. 32c, Water Temp. 21c)
WATER CONSUMPTION PER 24h	Approx. 0.060m ³ (Ambient Temp. 10c, Water Temp. 10c) Approx. 0.050m ³ (Ambient Temp. 21c, Water Temp. 15c) Approx. 0.038m ³ (Ambient Temp. 32c, Water Temp. 21c)
OUTSIDE DIMENSIONS	350mm(W)×585mm(D)×695(≈710)mm(H)
INSULATION FOAM BLOWING AGENT	HFC-245fa, 3665mfc
HEAT REJECTION	450W (Ambient Temp. 32c, Water Temp. 21c)
EXTERIOR	Stainless Steel (Side, Rear) ABS Molding (Front, Top, Drain Pan)
ICE MAKING SYSTEM	Thin ice forming inside Cylinder
CONNECTING-ELECTRIC	Y-Type Connection (with UK Plug)
CONNECTING-WATER SUPPLY	Direct Connection to Water Main, Inlet G3/4 (Bottom)
CONNECTING-DRAIN	Drain Hose, I.D. φ 25mm (Bottom)
HARVESTING SYSTEM	Direct driven Auger
ICE DISPENSING SYSTEM	Push Switch and Solenoid (with Select Switch) Portion control by Dispense Switch
WATER DISPENSING SYSTEM	Push Switch and Water Valve (with Select Switch) Portion control by Dispense Switch
COMPRESSOR	Hermetic
CONDENSER	Fin and Tube type, Air-cooled
EVAPORATOR	Tube coiled around Cylinder (Solder Plated)
REFRIGERANT	R134a
BIN CONTROL	Mechanical Bin Control (Time Delay Controlled)
ICE MAKING WATER CONTROL	Float Switch and Water Valve
REGIONAL CIRCUIT PROTECTION	10A Circuit Breaker
REFRIGERANT CHARGE PROTECTION	Compressor Internal Thermostat Condensing Temperature detected by Thermistor (Auto-reset)
INTERLOCK	Shutdown by Microprocessor (Manual-reset)
WEIGHT	Net: 47kg (Gross: 56kg)
PACKAGE	Carton 440mm(W)×655mm(D)×931mm(H)
ACCESSORIES	Installation Kit, Brush
OPERATING CONDITION	Ambient Temp.: 5-40 °C, Water Supply Temp.: 5-35c Water Supply Pressure: 0.05-0.78MPa Voltage Range: Rated Voltage±6%

*We reserve the right to make changes in specifications and design without prior notice.

[K] DCM-120KE (L009: Continental)

1. Install the ice maker properly in accordance with the instructions on location, water supply/drain connections and electrical connections stated in the instruction and installation manuals provided.
2. The ice production depends on the ambient and water temperatures. Refer to the instruction manual.
3. The amperage and electric consumption are based on measurements with the ice dispensing solenoid off.
4. Product Code: L009

ITEM	HOSHIZAKI CHIP ICE DISPENSER
MODEL	DCM-120KE
POWER SUPPLY	1 Phase 220-240/220-230V 50/60Hz Capacity: 0.84/0.81kVA (3.7/3.5A)
AMPERAGE	2.8/2.7A Starting: 12.6A
ELECTRIC CONSUMPTION	480/560W (Power Factor: 74/90%)
ICE PRODUCTION PER 24H	Approx. 125kg (Ambient Temp. 10°C, Water Temp. 10°C) Approx. 105kg (Ambient Temp. 21°C, Water Temp. 15°C) Approx. 85kg (Ambient Temp. 32°C, Water Temp. 21°C)
SHAPE OF ICE	Cubelet(Compressed Flake Ice)
STORAGE CAPACITY	Approx. 4.0kg
ICE DISPENSING RATE (40g/CUP)	Approx. 16cups/30min (Ambient Temp. 10°C, Water Temp. 10°C) Approx. 23cups/1hour (Ambient Temp. 10°C, Water Temp. 10°C) Approx. 15cups/30min (Ambient Temp. 21°C, Water Temp. 15°C) Approx. 20cups/1hour (Ambient Temp. 21°C, Water Temp. 15°C) Approx. 14cups/30min (Ambient Temp. 32°C, Water Temp. 21°C) Approx. 18cups/1hour (Ambient Temp. 32°C, Water Temp. 21°C)
WATER CONSUMPTION PER 24H	Approx. 0.125m ³ (Ambient Temp. 10°C, Water Temp. 10°C) Approx. 0.105m ³ (Ambient Temp. 21°C, Water Temp. 15°C) Approx. 0.085m ³ (Ambient Temp. 32°C, Water Temp. 21°C)
OUTSIDE DIMENSIONS	350mm(W)×585mm(D)×815mm(H)
INSULATION FOAM BLOWING AGENT	HFC-245fa, 365mfc
HEAT REJECTION	980/1180W (Ambient Temp. 32°C, Water Temp. 21°C)
EXTERIOR	Stainless Steel(Side, Rear)
ICE-MAKING SYSTEM	ABS Molding(Front, Top, Drain Pan)
CONNECTIONS-ELECTRIC	Thin ice forming inside Cylinder
CONNECTIONS-WATER SUPPLY	Y-Type Connection (with CONT. Plug)
CONNECTIONS-DRAIN	Direct Connection to Water Main, Inlet G3/4(Bottom)
HARVESTING SYSTEM	Drain Hose, I.D. φ 25mm(Bottom)
ICE DISPENSING SYSTEM	Direct driven Auger
WATER DISPENSING SYSTEM	Push Lever and Solenoid (with Select Switch)
COMPRESSOR	Portion control by Dispense Switch
CONDENSER	Push Lever and Water Valve (with Select Switch)
EVAPORATOR	Hermetic
REFRIGERANT	Fin and Tube type, Air-cooled
BIN CONTROL	Tube coiled around Cylinder (Solder Plated)
ELECTRICAL SAFETY PROTECTION	Mechanical Bin Control (Time Delay Controlled)
REFRIGERANT CIRCUIT PROTECTION	Float Switch and Water Valve
INTERLOCK	10A Circuit Breaker
WEIGHT	Compressor Internal Thermostat Condensing Temperature detected by Thermistor(Auto-reset) Shutdown by Microprocessor (Manual-reset) Net: 57kg(Gross: 66kg)
PACKAGING	Carton 440mm(W)×655mm(D)×1051mm(H)
ACCESSORIES	Installation Kit, Brush
OPERATING CONDITION	Ambient Temp.: 5-40°C, Water Supply Temp.: 5-35°C Water Supply Pressure: 0.05-0.78MPa Voltage Range: Rated Voltage±6%

*We reserve the right to make changes in specifications and design without prior notice.

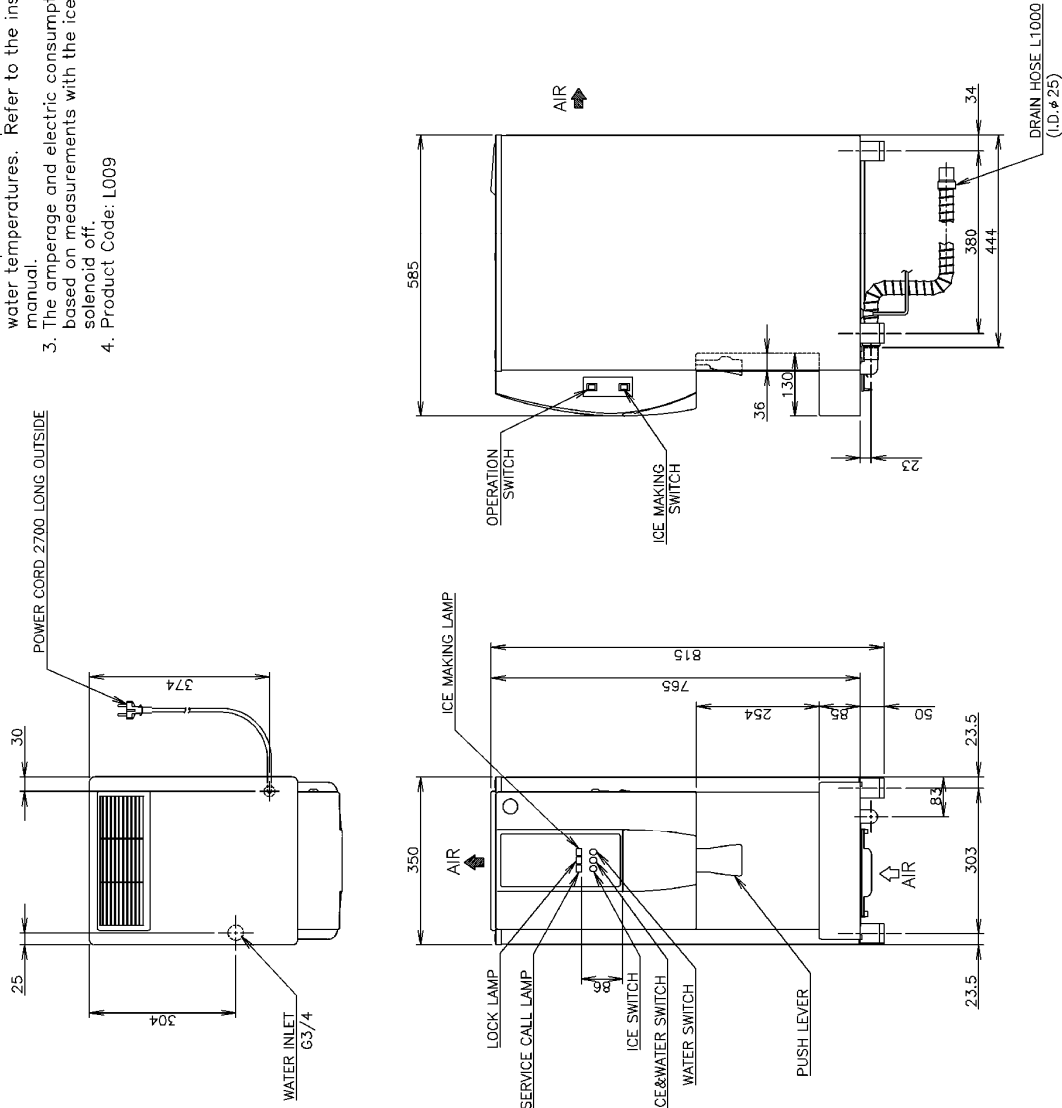

[I] DCM-120KE (L009-C101: UK)

1. Install the ice maker properly in accordance with the instructions on location, water supply/drain connections and electrical connections stated in the instruction and installation manuals provided.
2. The ice production depends on the ambient and water temperatures. Refer to the instruction manual.
3. The ampereage and electric consumption are based on measurements with the ice dispensing solenoid off.
4. Product Code: L009-C101

ITEM	HOSHIZAKI CHIP ICE DISPENSER
MODEL	DCM-120KE
POWER SUPPLY	1 Phase 220-240/220-230V 50/60Hz
AMPERAGE	Capacity: 0.84/0.81kVA (3.7/3.5A) 2.8/2.7A Starting: 12.6A
ELECTRIC CONSUMPTION	480/560W (Power Factor: 74/90%)
ICE PRODUCTION PER 24H	Approx. 125kg (Ambient Temp. 10°C, Water Temp. 10°C) Approx. 105kg (Ambient Temp. 21°C, Water Temp. 15°C) Approx. 85kg (Ambient Temp. 32°C, Water Temp. 21°C)
SHAPE OF ICE	Cubelet (Compressed Flake Ice)
STORAGE CAPACITY	Approx. 4.0kg
ICE DISPENSING RATE (40g/CUP)	Approx. 18cups/30min (Ambient Temp. 10°C, Water Temp. 10°C) Approx. 23cups/hour (Ambient Temp. 10°C, Water Temp. 10°C) Approx. 15cups/30min (Ambient Temp. 21°C, Water Temp. 15°C) Approx. 20cups/hour (Ambient Temp. 21°C, Water Temp. 15°C) Approx. 14cups/30min (Ambient Temp. 32°C, Water Temp. 21°C) Approx. 18cups/hour (Ambient Temp. 32°C, Water Temp. 21°C)
WATER CONSUMPTION PER 24H	Approx. 0.125m ³ /hour (Ambient Temp. 10°C, Water Temp. 10°C) Approx. 0.105m ³ /hour (Ambient Temp. 21°C, Water Temp. 15°C) Approx. 0.085m ³ /hour (Ambient Temp. 32°C, Water Temp. 21°C)
OUTSIDE DIMENSIONS	350mm(W)×585mm(D)×815mm(H)
INSULATION FOAM BLOWING AGENT	HFC-245fa, 365mfc
HEAT REJECTION	980/1180W (Ambient Temp. 32°C, Water Temp. 21°C)
EXTERIOR	Stainless Steel (Side, Rear) ABS Molding (Front, Top, Drain Pan)
ICE MAKING SYSTEM	Thin ice forming inside Cylinder
CONNECTING-ELECTRIC	Y-Type Connection (with UK Plug)
CONNECTING-WATER SUPPLY	Direct Connection to Water Main Inlet G3/4 (Bottom)
CONNECTIONS-DRAIN	Drain Hose, I.D. φ 25mm (Bottom)
HARVESTING SYSTEM	Direct driven Auger
ICE DISPENSING SYSTEM	Push Lever and Solenoid (with Select Switch) Portion control by Dispense Switch
WATER DISPENSING SYSTEM	Push Lever and Water Valve (with Select Switch)
COMPRESSOR	Hermetic
CONDENSER	Fin and Tube type, Air-cooled
EVAPORATOR	Tube coiled around Cylinder (Solder Plated)
REFRIGERANT	R134a
BIN CONTROL	Mechanical Bin Control (Time Delay Controlled)
ICE MAKING WATER CONTROL	Float Switch and Water Valve
ELECTRICAL CIRCUIT PROTECTION	10A Circuit Breaker Compressor Internal Thermostat Condensing Temperature detected by Thermistor (Auto-reset)
INTERLOCK	Shutdown by Microprocessor (Manual-reset)
WEIGHT	Net: 57kg (Gross: 66kg)
PACKAGE	Carton 440mm(W)×655mm(D)×1051mm(H)
ACCESSORIES	Installation Kit, Brush
OPERATING CONDITION	Ambient Temp.: 5-35°C, Water Supply Temp.: 5-35°C Water Supply Pressure: 0.05-0.78MPa Voltage Range: Rated Voltage±6%

*We reserve the right to make changes in specifications and design without prior notice.

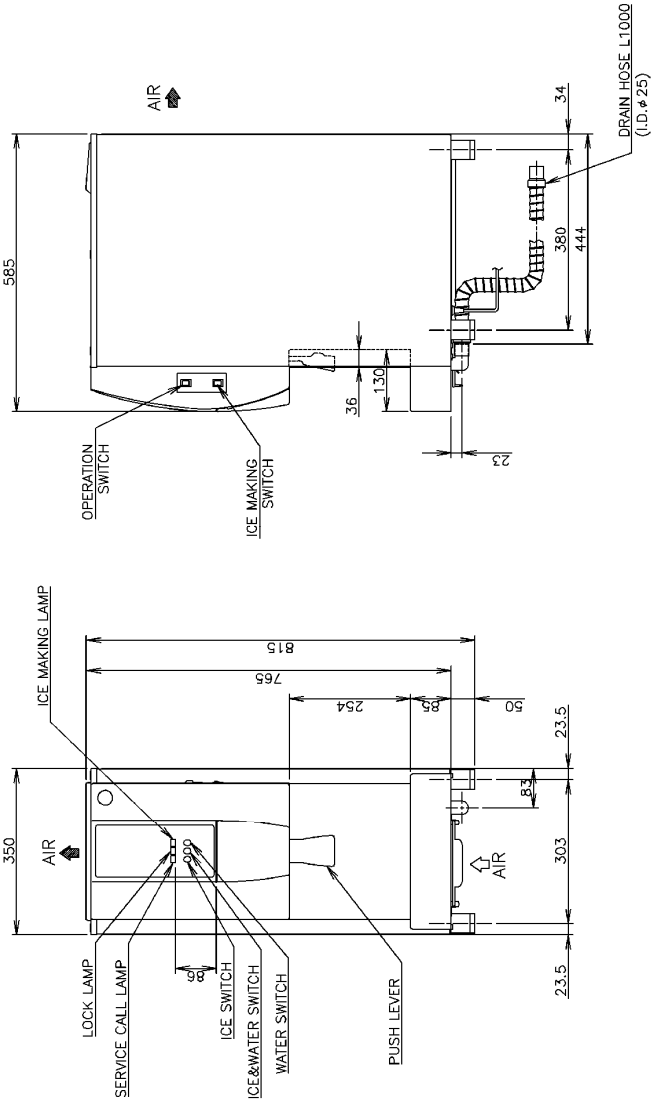
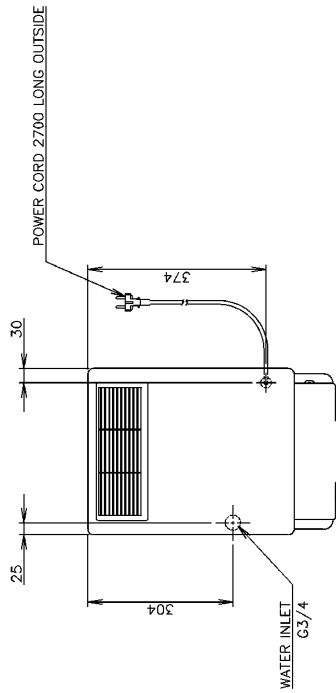

[m] DCM-120KE (L009-C201: Oceania)

1. Install the ice maker properly in accordance with the instructions on location, water supply/drain connections and electrical connections stated in the instruction and installation manuals provided.
2. The ice production depends on the ambient and water temperatures. Refer to the instruction manual.
3. The ampereage and electric consumption are based on measurements with the ice dispensing solenoid off.
4. Product Code: L009-C201

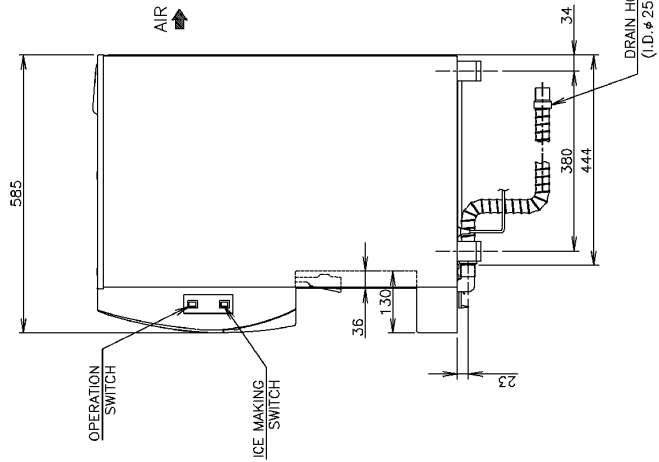
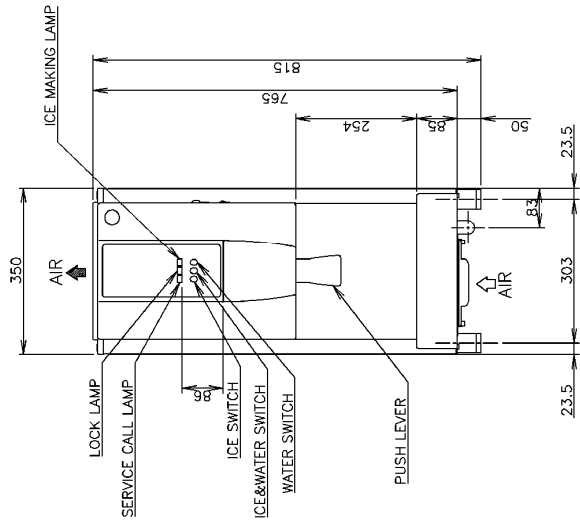
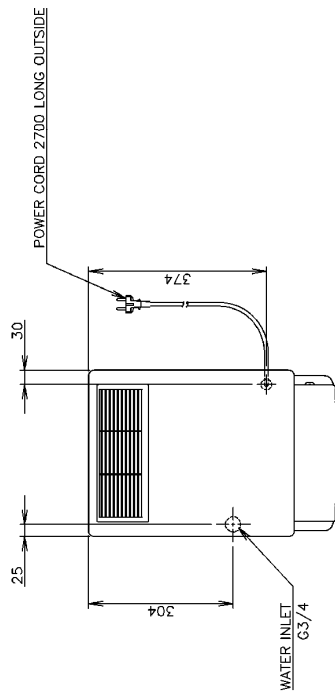

ITEM	HOSHIZAKI CHIP ICE DISPENSER
MODEL	DCM-120KE
POWER SUPPLY	1 Phase 220-240/220-230V 50/60Hz Capacity: 0.84/0.81kVA (3.7/3.5A)
AMPERAGE	2.8/2.7A Starting: 12.6A
ELECTRIC CONSUMPTION	480/560W (Power Factor: 74/90%)
ICE PRODUCTION PER 24H	Approx. 125kg (Ambient Temp. 10°C, Water Temp. 10°C) Approx. 105kg (Ambient Temp. 21°C, Water Temp. 15°C) Approx. 85kg (Ambient Temp. 32°C, Water Temp. 21°C)
SHAPE OF ICE	Cubelet (Compressed Flake Ice)
STORAGE CAPACITY	Approx. 4.0kg
ICE DISPENSING RATE (40g/CUP)	Approx. 16cups/30min (Ambient Temp. 10°C, Water Temp. 10°C)
	Approx. 23cups/1hour (Ambient Temp. 10°C, Water Temp. 10°C)
	Approx. 15cups/30min (Ambient Temp. 21°C, Water Temp. 15°C)
	Approx. 20cups/1hour (Ambient Temp. 21°C, Water Temp. 15°C)
WATER CONSUMPTION PER 24H	Approx. 14cups/30min (Ambient Temp. 32°C, Water Temp. 21°C)
	Approx. 18cups/1hour (Ambient Temp. 32°C, Water Temp. 21°C)
	Approx. 0.125m ³ /Ambient Temp. 10°C, Water Temp. 10°C
OUTSIDE DIMENSIONS	Approx. 0.105m ³ /Ambient Temp. 21°C, Water Temp. 15°C
	Approx. 0.085m ³ /Ambient Temp. 32°C, Water Temp. 21°C
INSULATION FOAM BLOWING AGENT	350mm (W) x 585mm (D) x 815 (~830)mm (H)
HEAT REJECTION	HFC-245fa, 365mfc
EXTERIOR	980/1180W (Ambient Temp. 32°C, Water Temp. 21°C)
ICE MAKING SYSTEM	Stainless Steel (Side, Rear)
CONNECTIONS-ELECTRIC	ABS Molding (Front, Top, Drain Pan)
CONNECTIONS-WATER SUPPLY	Thin ice forming inside Cylinder
CONNECTIONS-DRAIN	Y-Type Connection (with OCEANIA Plug)
HARVESTING SYSTEM	Direct Connection to Water Main, Inlet G3/4 (Bottom)
ICE DISPENSING SYSTEM	Drain Hose, I.D. # 25mm (Bottom)
WATER DISPENSING SYSTEM	Direct driven Auger
COMPRESSOR	Push Lever and Solenoid (with Select Switch)
CONDENSER	Portion control by Dispense Switch
EVAPORATOR	Push Lever and Water Valve (with Select Switch)
REFRIGERANT	Hermetic
ICE MAKING WATER CONTROL	Fin and Tube type, Air-cooled
ELECTRICAL CONTROL PROTECTION	Tube coiled around Cylinder (Solder Plated)
INTERLOCK	R134a
WEIGHT	Mechanical Bin Control (Time Delay Controlled)
PACKAGE	Float Switch and Water Valve
ACCESSORIES	10A Circuit Breaker
OPERATING CONDITION	Refrigerant Internal Thermostat Condensing Temperature detected by Thermostat (Auto-reset) Shutdown by Microprocessor (Manual-reset)
	Net: 57kg (Gross: 66kg)
	Carton 440mm (W) x 655mm (D) x 1051mm (H)
	Installation Kit, Brush
	Ambient Temp.: 5-40° C, Water Supply Temp.: 5-35°C
	Water Supply Pressure: 0.05-0.78MPa
	Voltage Range: Rated Voltage ± 6%

*We reserve the right to make changes in specifications and design without prior notice.

[n] DCM-120KE (L009-C301: China)

1. Install the ice maker properly in accordance with the instructions on location, water supply/drain connections and electrical connections stated in the instruction and installation manuals provided.
2. The ice production depends on the ambient and water temperatures. Refer to the instruction manual.
3. The amperage and electric consumption are based on measurements with the ice dispensing solenoid off.
4. Product Code: L009-C301

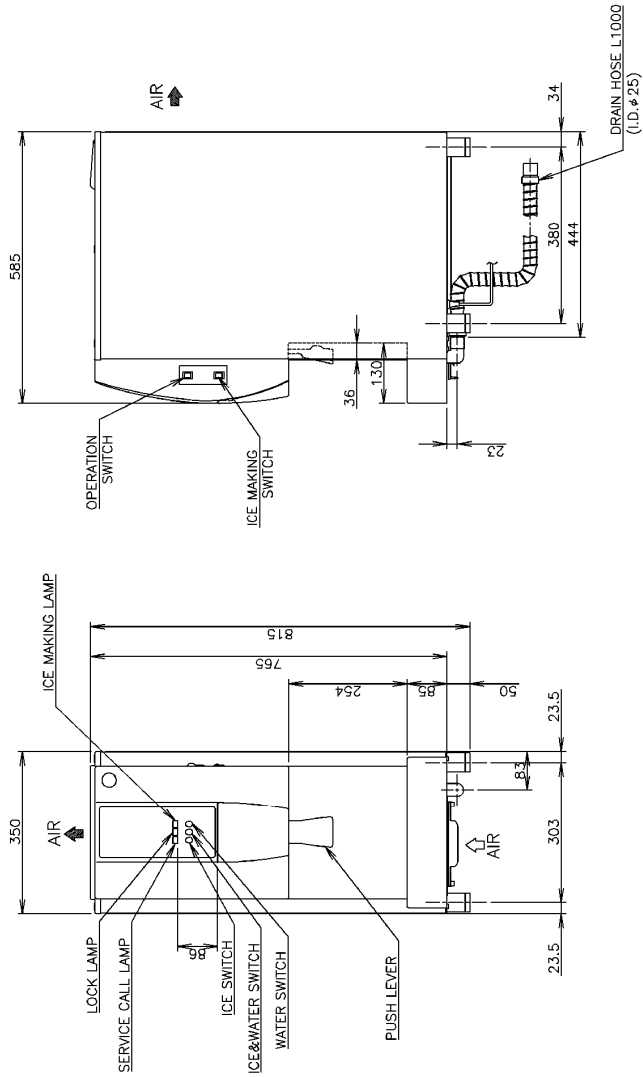
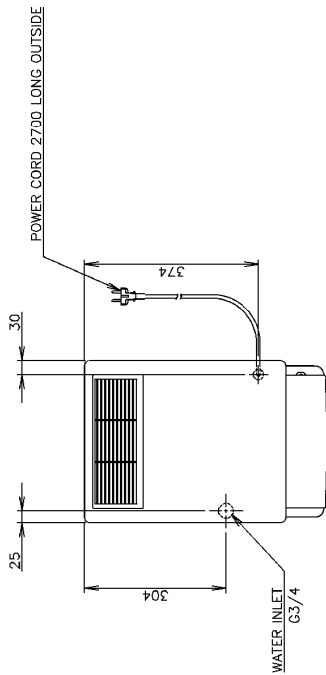

ITEM	HOSHIZAKI CHIP ICE DISPENSER
MODEL	DCM-120KE
POWER SUPPLY	1 Phase 220-240/220-230V 50/60Hz Capacity: 0.84/0.81kVA (3.7/3.5A)
AMPERAGE	2.8/2.7A Starting: 12.6A
ELECTRIC CONSUMPTION	480/560W (Power Factor: 74/90%)
ICE PRODUCTION PER 24H	Approx. 125kg (Ambient Temp. 10C, Water Temp. 10C) Approx. 105kg (Ambient Temp. 21C, Water Temp. 15C) Approx. 85kg (Ambient Temp. 32C, Water Temp. 21C)
SHAPE OF ICE	Cubelet (Compressed Flake Ice)
STORAGE CAPACITY	Approx. 4.0kg Approx. 165cups/30min (Ambient Temp. 10C, Water Temp. 10C) Approx. 230cups/1hour (Ambient Temp. 10C, Water Temp. 10C) Approx. 154cups/20min (Ambient Temp. 21C, Water Temp. 15C) Approx. 208cups/1hour (Ambient Temp. 21C, Water Temp. 15C) Approx. 144cups/30min (Ambient Temp. 32C, Water Temp. 21C) Approx. 188cups/1hour (Ambient Temp. 32C, Water Temp. 21C)
ICE DISPENSING RATE (40g/CUP)	Approx. 0.125m ³ /hour (Ambient Temp. 10C, Water Temp. 10C) Approx. 0.105m ³ /hour (Ambient Temp. 21C, Water Temp. 15C) Approx. 0.085m ³ /hour (Ambient Temp. 32C, Water Temp. 21C)
WATER CONSUMPTION PER 24H	Approx. 0.105m ³ /hour (Ambient Temp. 10C, Water Temp. 10C) Approx. 0.085m ³ /hour (Ambient Temp. 21C, Water Temp. 15C) Approx. 0.085m ³ /hour (Ambient Temp. 32C, Water Temp. 21C)
OUTSIDE DIMENSIONS	350mm(W)×585mm(D)×815mm(H)
INSULATION FOAM BLOWING AGENT	HFC-245fa, 365mfc
HEAT REJECTION	980/1180W (Ambient Temp. 32C, Water Temp. 21C)
EXTERIOR	Stainless Steel (Side, Rear) ABS Molding (Front, Top, Drain Pan)
ICE MAKING SYSTEM	Thin ice forming inside Cylinder
CONNECTING-ELECTRIC	Y-Type Connection (with CHINA Plug)
CONNECTING-WATER SUPPLY	Direct Connection to Water Main Inlet G3/4 (Bottom)
CONNECTING-DRAIN	Drain Hose, I.D. φ 25mm (Bottom)
HARVESTING SYSTEM	Direct driven Auger
ICE DISPENSING SYSTEM	Push Lever and Solenoid (with Select Switch) Portion control by Dispense Switch
WATER DISPENSING SYSTEM	Push Lever and Water Valve (with Select Switch)
COMPRESSOR	Hermetic
CONDENSER	Fin and Tube type, Air-cooled
EVAPORATOR	Tube coiled around Cylinder (Solder Plated)
REFRIGERANT	R134a
BIN CONTROL	Mechanical Bin Control (Time Delay Controlled)
ICE MAKING WATER CONTROL	Float Switch and Water Valve
ELECTRICAL CIRCUIT PROTECTION	10A Circuit Breaker
REFRIGERANT CIRCUIT PROTECTION	Compressor Internal Thermostat Condensing Temperature detected by Thermistor (Auto-reset)
INTERLOCK	Shutdown by Microprocessor (Manual-reset)
WEIGHT	Net: 57kg (Gross: 66kg)
PACKAGE	Carton 440mm(W)×655mm(D)×1051mm(H)
ACCESSORIES	Installation Kit, Brush
OPERATING CONDITION	Ambient Temp.: 5-40° C, Water Supply Temp.: 5-35C Water Supply Pressure: 0.05-0.78MPa Voltage Range: Rated Voltage±6%

We reserve the right to make changes in specifications and design without prior notice.

[o] DCM-120KE-P (L010: Continental)

1. Install the ice maker properly in accordance with the instructions on location, water supply/drain connections and electrical connections stated in the instruction and installation manuals provided.
2. The ice production depends on the ambient and water temperatures. Refer to the instruction manual.
3. The ampere and electric consumption are based on measurements with the ice dispensing solenoid off.
4. Product Code: L010

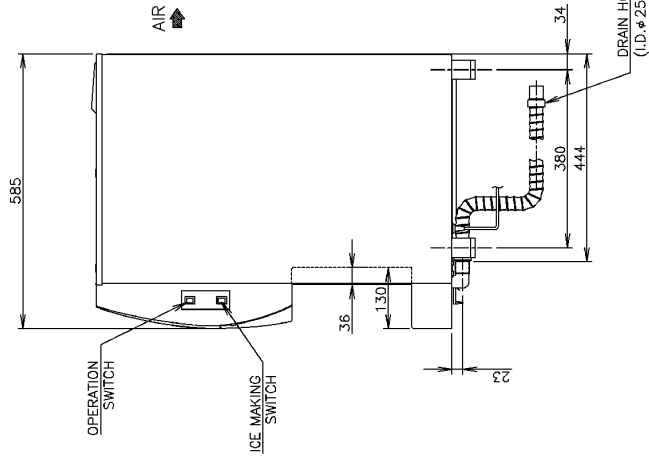
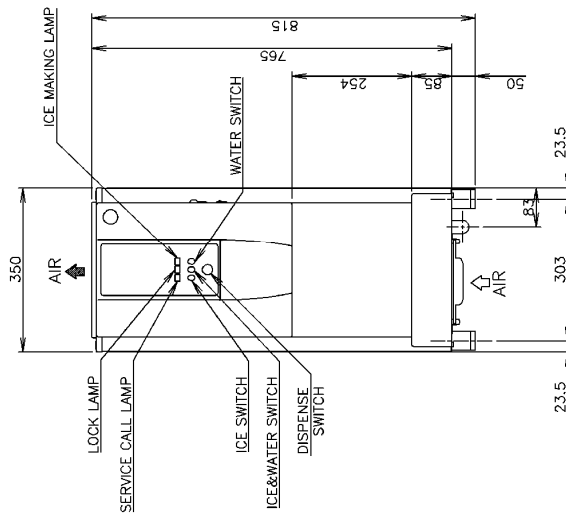
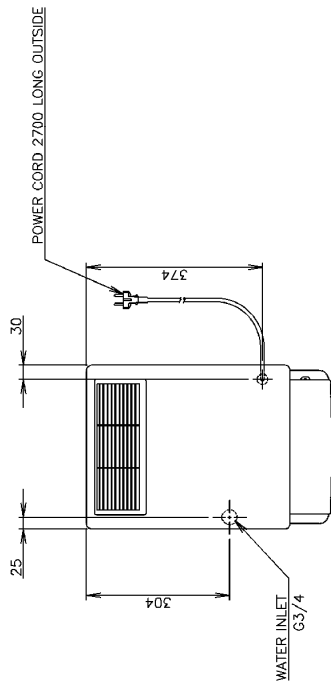

ITEM	HOSHIZAKI CHIP ICE DISPENSER
MODEL	DCM-120KE-P
POWER SUPPLY	1 Phase 220-240/220-230V 50/60Hz Capacity: 0.84/0.81kVA (3.7/3.5A)
AMPERAGE	2.8/2.7A Starting: 12.6A
ELECTRIC CONSUMPTION	480/560W (Power Factor: 74/90%) Approx. 125kg (Ambient Temp. 10°C, Water Temp. 10°C) Approx. 135kg (Ambient Temp. 21°C, Water Temp. 15°C) Approx. 85kg (Ambient Temp. 32°C, Water Temp. 21°C)
ICE PRODUCTION PER 24h	
SHAPE OF ICE	Cubelet (Compressed Flake Ice)
STORAGE CAPACITY	Approx. 4.0kg Approx. 165cups/30min (Ambient Temp. 10°C, Water Temp. 10°C) Approx. 230cups/1hour (Ambient Temp. 10°C, Water Temp. 10°C) Approx. 15cups/30min (Ambient Temp. 21°C, Water Temp. 15°C) Approx. 20cups/1hour (Ambient Temp. 21°C, Water Temp. 15°C) Approx. 14cups/30min (Ambient Temp. 32°C, Water Temp. 21°C) Approx. 18cups/1hour (Ambient Temp. 32°C, Water Temp. 21°C)
WATER CONSUMPTION PER 24h	Approx. 0.125m ³ (Ambient Temp. 10°C, Water Temp. 10°C) Approx. 0.105m ³ (Ambient Temp. 21°C, Water Temp. 15°C) Approx. 0.085m ³ (Ambient Temp. 32°C, Water Temp. 15°C)
OUTSIDE DIMENSIONS	350mm(W)×585mm(D)×815(~830)mm(H)
INSULATION FOAM BLOWING AGENT	HFC-245fa, 365mfc
HEAT REJECTION	980/1183W (Ambient Temp. 32°C, Water Temp. 21°C)
EXTERIOR	Stainless Steel (Side, Rear) ABS Molding (Front, Top, Drain Pan)
ICE MAKING SYSTEM	Thin ice forming inside Cylinder
CONNECTING-ELECTRIC	Y-Type Connection (with CONT. Plug)
CONNECTING-WATER SUPPLY	Direct Connection to Water Main, Inlet G3/4 (Bottom)
CONNECTIONS-DRAIN	Drain Hose, I.D. φ 25mm (Bottom)
HARVESTING SYSTEM	Direct driven Auger
ICE DISPENSING SYSTEM	Push Switch and Solenoid (with Select Switch) Portion control by Dispense Switch
WATER DISPENSING SYSTEM	Push Switch and Water Valve (with Select Switch) Portion control by Dispense Switch
COMPRESSOR	Hermetic
CONDENSER	Fin and Tube type, Air-cooled
EVAPORATOR	Tube coiled around Cylinder (Solder Plated)
REFRIGERANT	R134a
ICE MAKING CONTROL	Mechanical Bin Control (Time Delay Controlled) Float Switch and Water Valve
ELECTRICAL CIRCUIT PROTECTION	10A Circuit Breaker Compressor Internal Thermostat Condensing Temperature detected by Thermistor (Auto-reset)
INTERLOCK	Shutdown by Microprocessor (Manual-reset)
WEIGHT	Net: 57kg (Gross: 66kg)
PACKAGE	Carton 440mm(W)×655mm(D)×1051mm(H)
ACCESSORIES	Installation Kit, Brush
OPERATING CONDITION	Ambient Temp.: 5-40° C, Water Supply Temp.: 5-35°C Water Supply Pressure: 0.05-0.7MPa Voltage Range: Rated Voltage±5%

*We reserve the right to make changes in specifications and design without prior notice.

[p] DCM-120KE-P (L010-C101: UK)

1. Install the ice maker properly in accordance with the instructions on location, water supply/drain connections and electrical connections stated in the instruction and installation manuals provided.
2. The ice production depends on the ambient and water temperatures. Refer to the instruction manual.
3. The amperage and electric consumption are based on measurements with the ice dispensing solenoid off.
4. Product Code: L010-C101

ITEM	HOSHIZAKI CHIP ICE DISPENSER
MODEL	DCM-120KE-P
POWER SUPPLY	1 Phase 220-240/220-230V 50/60Hz Capacity: 0.84/0.81kVA (3.7/3.5A)
AMPERAGE	2.8/2.7A Starting: 12.6A
ELECTRIC CONSUMPTION	480/550W (Power Factor: 74/90%)
ICE PRODUCTION PER 24H	Approx. 125kg (Ambient Temp. 10c, Water Temp. 10c) Approx. 105kg (Ambient Temp. 21c, Water Temp. 15c) Approx. 85kg (Ambient Temp. 32c, Water Temp. 21c)
SHAPE OF ICE	Cubelet (Compressed Flake Ice)
STORAGE CAPACITY	Approx. 4.0kg
ICE DISPENSING RATE (40g/CUP)	Approx. 16cups/30min (Ambient Temp. 10c, Water Temp. 10c)
	Approx. 23cups/1hour (Ambient Temp. 10c, Water Temp. 10c)
	Approx. 15cups/30min (Ambient Temp. 21c, Water Temp. 15c)
	Approx. 20cups/1hour (Ambient Temp. 21c, Water Temp. 15c)
	Approx. 14cups/30min (Ambient Temp. 32c, Water Temp. 21c)
WATER CONSUMPTION PER 24H	Approx. 188cups/1hour (Ambient Temp. 32c, Water Temp. 21c)
	Approx. 0.125m ³ /Ambient Temp. 10c, Water Temp. 10c
	Approx. 0.105m ³ /Ambient Temp. 21c, Water Temp. 15c
OUTSIDE DIMENSIONS	Approx. 0.385m ³ /Ambient Temp. 32c, Water Temp. 21c
INSULATION FOAM BLOWING AGENT	350mm(W) x 585mm(D) x 815 (~830)mm(H)
HEAT REJECTION	HFC-245fa, 365mfc
EXTERIOR	980/1180W (Ambient Temp. 32c, Water Temp. 21c)
ICE MAKING SYSTEM	Stainless Steel (Side, Rear)
CONNECTIONS-ELECTRIC	ABS Molding (Front, Top, Drain Pan)
CONNECTING-WATER SUPPLY	Thin ice forming inside Cylinder
CONNECTIONS-DRAIN	Y-Type Connection (with UK. Plug)
HARVESTING SYSTEM	Direct Connection to Water Main, Inlet G3/4 (Bottom)
ICE DISPENSING SYSTEM	Drain Hose, I.D. φ 25mm (Bottom)
WATER DISPENSING SYSTEM	Direct driven Auger
COMPRESSOR	Push Switch and Solenoid (with Select Switch)
CONDENSER	Portion control by Dispense Switch
EVAPORATOR	Push Switch and Water Valve (with Select Switch)
REFRIGERANT	Portion control by Dispense Switch
BIN CONTROL	Hermetic
ICE MAKING WATER CONTROL	Fin and Tube type, Air-cooled
ELECTRICAL SAFETY PROTECTION	Tube coiled around Cylinder (Solder Plated)
INTERLOCK	R134a
WEIGHT	Mechanical Bin Control (Time Delay Controlled)
PACKAGING	Float Switch and Water Valve
ACCESSORIES	10A Circuit Breaker
OPERATING CONDITION	Compressor Internal Thermostat Condensing Temperature detected by Thermistor (Auto-reset) Shutdown by Microprocessor (Manual-reset)
	Net: 57kg (Gross: 86kg)
	Carbon 440mm(W) x 655mm(D) x 1051mm(H)
	Installation Kit, Brush
	Ambient Temp.: 5-40 C, Water Supply Temp.: 5-35c
	Water Supply Pressure: 0.05-0.78MPa
	Voltage Range: Rated Voltage ± 6%

*We reserve the right to make changes in specifications and design without prior notice.

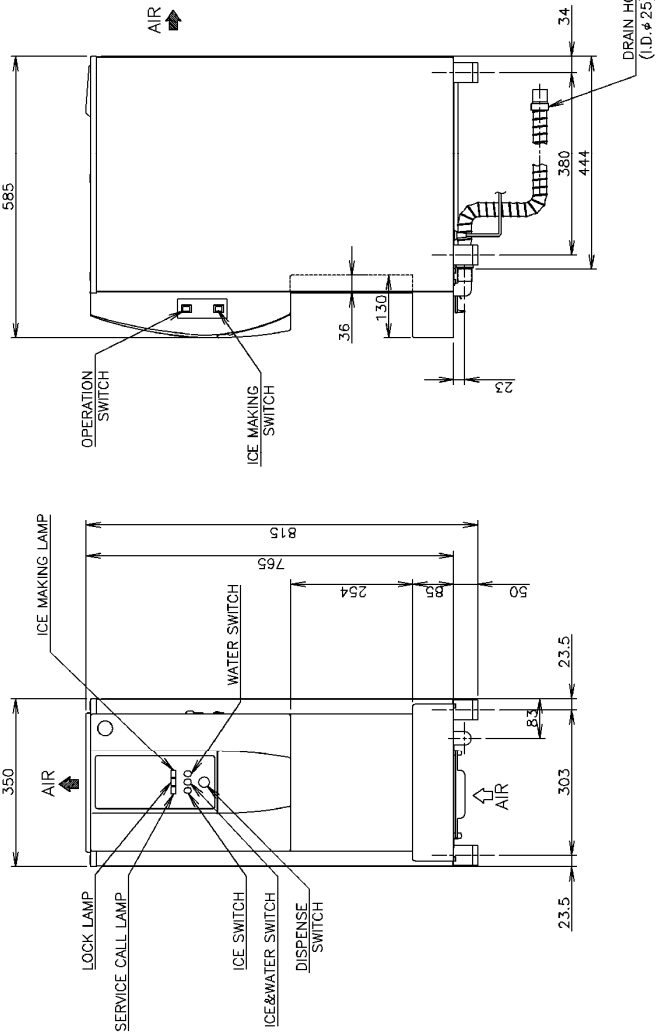
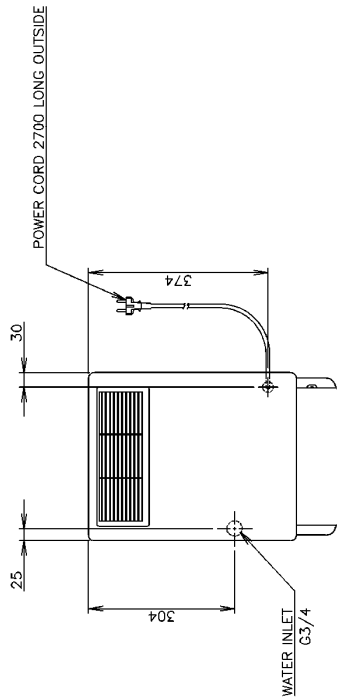

[q] DCM-120KE-P (L010-C201: Oceania)

1. Install the ice maker properly in accordance with the instructions on location, water supply/drain connections and electrical connections stated in the instruction and installation manuals provided.
2. The ice production depends on the ambient and water temperatures. Refer to the instruction manual.
3. The amperage and electric consumption are based on measurements with the ice dispensing solenoid off.
4. Product Code: L010-C201

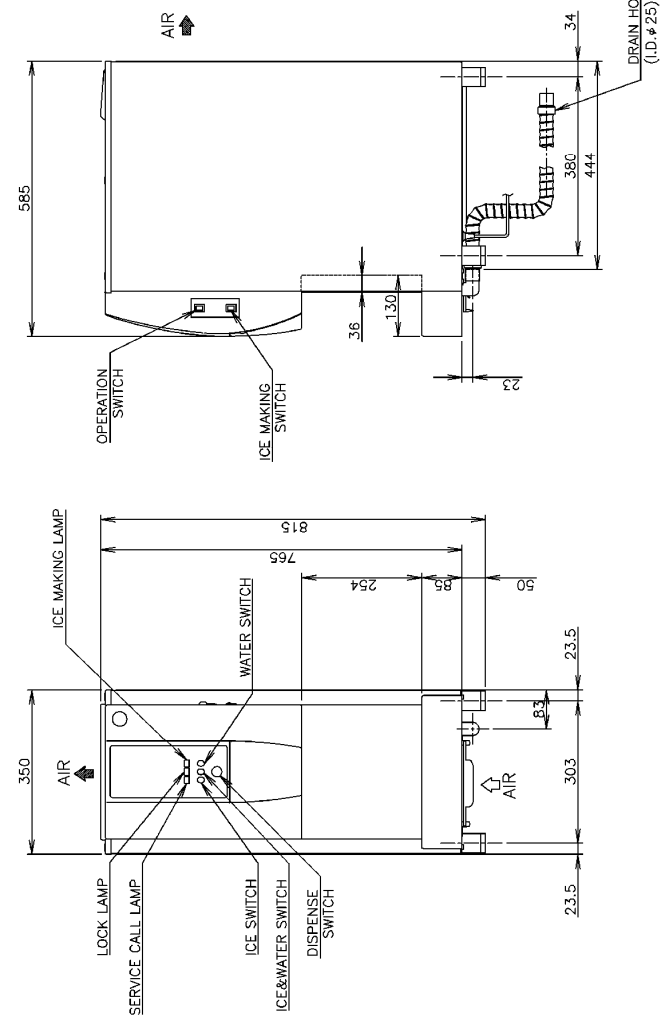
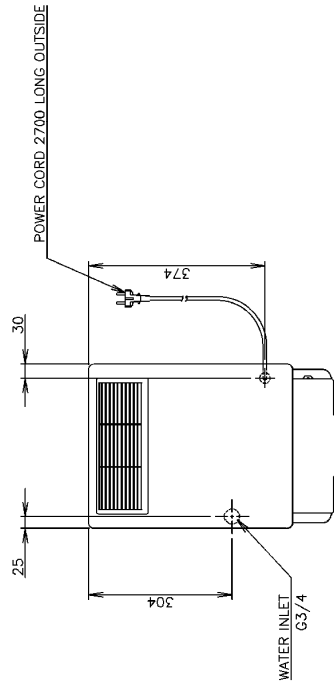

ITEM	HOSHIZAKI CHIP ICE DISPENSER
MODEL	DCM-120KE-P
POWER SUPPLY	1 Phase 220-240/220-230V 50/60Hz Capacity: 0.84/0.81kVA (3.7/3.5A)
AMPERAGE	2.8/2.7A Starting: 12.6A
ELECTRIC CONSUMPTION	480/560W (Power Factor: 74/90%)
ICE PRODUCTION PER 24H	Approx. 125kg (Ambient Temp. 10°C, Water Temp. 10°C) Approx. 105kg (Ambient Temp. 21°C, Water Temp. 15°C) Approx. 85kg (Ambient Temp. 32°C, Water Temp. 21°C)
SHAPE OF ICE	Cubelet (Compressed Flake Ice)
STORAGE CAPACITY	Approx. 4.0kg Approx. 165cups/30min (Ambient Temp. 10°C, Water Temp. 10°C) Approx. 230cups/1hour (Ambient Temp. 10°C, Water Temp. 10°C) Approx. 150cups/30min (Ambient Temp. 21°C, Water Temp. 15°C) Approx. 200cups/1hour (Ambient Temp. 21°C, Water Temp. 15°C) Approx. 140cups/30min (Ambient Temp. 32°C, Water Temp. 21°C) Approx. 180cups/1hour (Ambient Temp. 32°C, Water Temp. 21°C)
WATER CONSUMPTION PER 24H	Approx. 0.125m ³ (Ambient Temp. 10°C, Water Temp. 10°C) Approx. 0.105m ³ (Ambient Temp. 21°C, Water Temp. 15°C) Approx. 0.085m ³ (Ambient Temp. 32°C, Water Temp. 15°C)
OUTSIDE DIMENSIONS	350mm(W) x 585mm(D) x 815mm(H)
INSULATION FOAM BLOWING AGENT	HFC-245fa, 365mfc
HEAT REJECTION	980/1180W (Ambient Temp. 32°C, Water Temp. 21°C)
EXTERIOR	Stainless Steel (Side, Rear) ABS Molding (Front, Top, Drain Pan)
ICE MAKING SYSTEM	Thin ice forming inside Cylinder
CONNECTING-ELECTRIC	Y-Type Connection (with OCEANIA, Plug)
CONNECTING-WATER SUPPLY	Direct Connection to Water Main, Inlet G3/4 (Bottom)
CONNECTING-DRAIN	Drain Hose, I.D. Ø 25mm (Bottom)
HARVESTING SYSTEM	Direct driven Auger
ICE DISPENSING SYSTEM	Push Switch and Solenoid (with Select Switch) Portion control by Dispense Switch
WATER DISPENSING SYSTEM	Push Switch and Water Valve (with Select Switch) Portion control by Dispense Switch
COMPRESSOR	Hermetic
CONDENSER	Fin and Tube type, Air-cooled
EVAPORATOR	Tube coiled around Cylinder (Solder Plated)
REFRIGERANT	R134a
BIN CONTROL	Mechanical Bin Control (Time Delay Controlled)
ICE MAKING WATER CONTROL	Float Switch and Water Valve
ELECTRICAL PROTECTION	10A Circuit Breaker
REFRIGERANT CIRCUIT PROTECTION	Compressor Internal Thermostat Condensing Temperature detected by Thermostat (Auto-reset)
INTERLOCK	Shutdown by Microprocessor (Manual-reset)
WEIGHT	Net: 57kg (Gross: 66kg)
PACKAGE	Carton 440mm(W) x 655mm(D) x 1051mm(H)
ACCESSORIES	Installation Kit, Brush
OPERATING CONDITION	Ambient Temp.: 5-40° C, Water Supply Temp.: 5-35°C Water Supply Pressure: 0.05-0.78MPa Voltage Range: Rated Voltage ± 6%

*We reserve the right to make changes in specifications and design without prior notice.

[r] DCM-120KE-P (L010-C301: China)

1. Install the ice maker properly in accordance with the instructions on location, water supply/drain connections and electrical connections stated in the instruction and installation manuals provided.
2. The ice production depends on the ambient and water temperatures. Refer to the instruction manual.
3. The ampereage and electric consumption are based on measurements with the ice dispensing solenoid off.
4. Product Code: L010-C301

ITEM	HOSHIZAKI CHIP ICE DISPENSER
MODEL	DCM-120KE-P
POWER SUPPLY	1 Phase 220-240/220-230V 50/60Hz Capacity: 0.84/0.81kVA (3.7/3.5A)
AMPERAGE	2.8/2.7A Starting: 12.6A
ELECTRIC CONSUMPTION	4.80/5.60W (Power Factor: 74/90%)
ICE PRODUCTION PER 24h	Approx. 125kg (Ambient Temp. 10c, Water Temp. 10c) Approx. 105kg (Ambient Temp. 21c, Water Temp. 15c) Approx. 85kg (Ambient Temp. 32c, Water Temp. 21c)
SHAPE OF ICE	Cubelet(Compressed Flake Ice)
STORAGE CAPACITY	Approx. 4.0kg
ICE DISPENSING RATE (40g/CUP)	Approx. 185cups/30min (Ambient Temp. 10c, Water Temp. 10c)
	Approx. 230cups/1hour(Ambient Temp. 10c, Water Temp. 10c)
	Approx. 15cups/30min (Ambient Temp. 21c, Water Temp. 15c)
	Approx. 20cups/1hour (Ambient Temp. 21c, Water Temp. 15c)
	Approx. 14cups/30min (Ambient Temp. 32c, Water Temp. 21c)
WATER CONSUMPTION PER 24h	Approx. 0.125m ³ (Ambient Temp. 10c, Water Temp. 10c)
	Approx. 0.105m ³ (Ambient Temp. 21c, Water Temp. 15c)
OUTSIDE DIMENSIONS	Approx. 0.085m ³ (Ambient Temp. 32c, Water Temp. 21c) 350mm(W)×585mm(D)×815(~830)mm(H)
INSULATION FOAM BLOWING AGENT	HFC-245fa, 365mfc
HEAT REJECTION	980/1183W (Ambient Temp. 32c, Water Temp. 21c)
EXTERIOR	Stainless Steel(Side, Rear) ABS Molding(Front, Top, Drain Pan)
ICE MAKING SYSTEM	Thin ice forming inside Cylinder
CONNECTIONS-ELECTRIC	Y-Type Connection (with CHINA Plug)
CONNECTIONS-WATER SUPPLY	Direct Connection to Water Main, Inlet G3/4(Bottom)
CONNECTIONS-DRAIN	Drain Hose, I.D. φ 25mm(Bottom)
HARVESTING SYSTEM	Direct driven Auger
ICE DISPENSING SYSTEM	Push Switch and Solenoid (with Select Switch) Portion control by Dispense Switch
WATER DISPENSING SYSTEM	Push Switch and Water Valve(with Select Switch) Portion control by Dispense Switch
COMPRESSOR	Hermetic
CONDENSER	Fin and Tube type, Air-cooled
EVAPORATOR	Tube coiled around Cylinder (Solder Plated)
REFRIGERANT	R134a
BIN CONTROL	Mechanical Bin Control (Time Delay Controlled)
ICE MAKING WATER CONTROL	Floot Switch and Water Valve
ELECTRICAL CIRCUIT PROTECTION	10A Circuit Breaker
REFRIGERANT CIRCUIT PROTECTION	Compressor Internal Thermostat Condensing Temperature detected by Thermistor(Auto-reset)
INTERLOCK	Shutdown by Microprocessor (Manual-reset)
WEIGHT	Net: 57kg(Gross: 66kg)
PACKAGE	Carton 440mm(W)×655mm(D)×1051mm(H)
ACCESSORIES	Installation Kit, Brush
OPERATING CONDITION	Ambient Temp.: 5-40° C, Water Supply Temp.: 5-35c Water Supply Pressure: 0.05-0.78MPa Voltage Range: Rated Voltage±6%

*We reserve the right to make changes in specifications and design without prior notice.

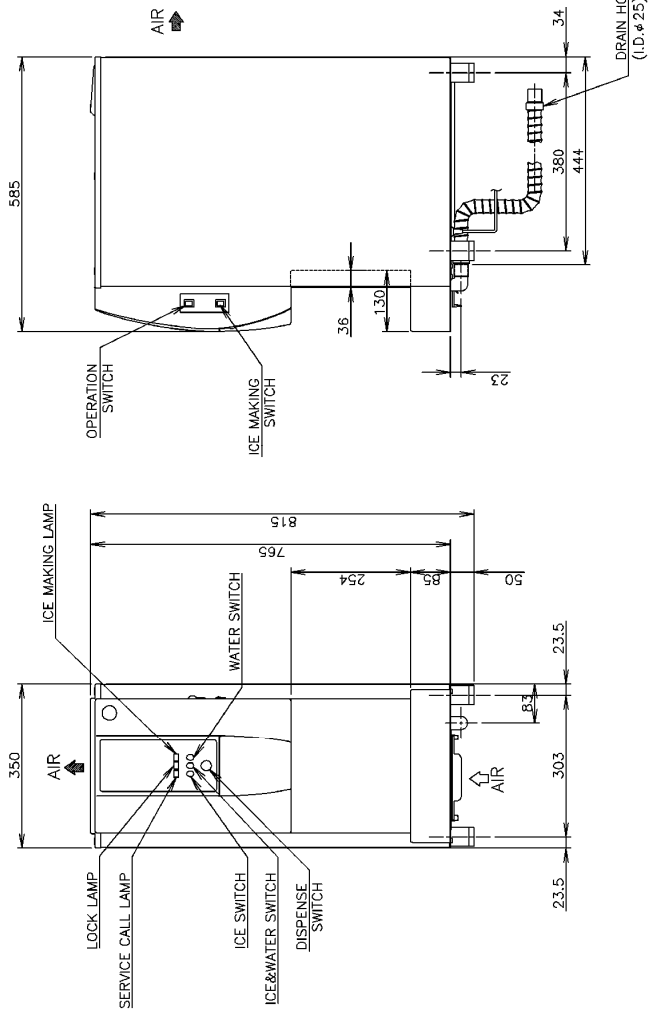
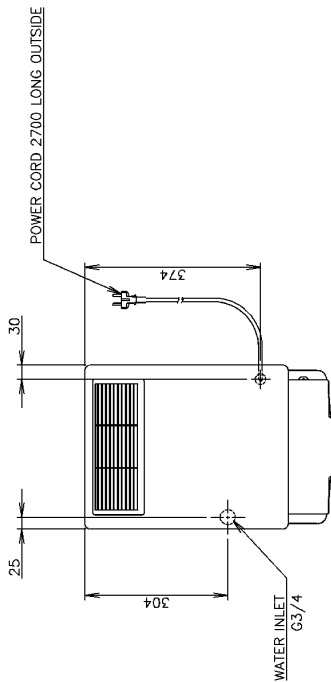

2. CONSTRUCTION

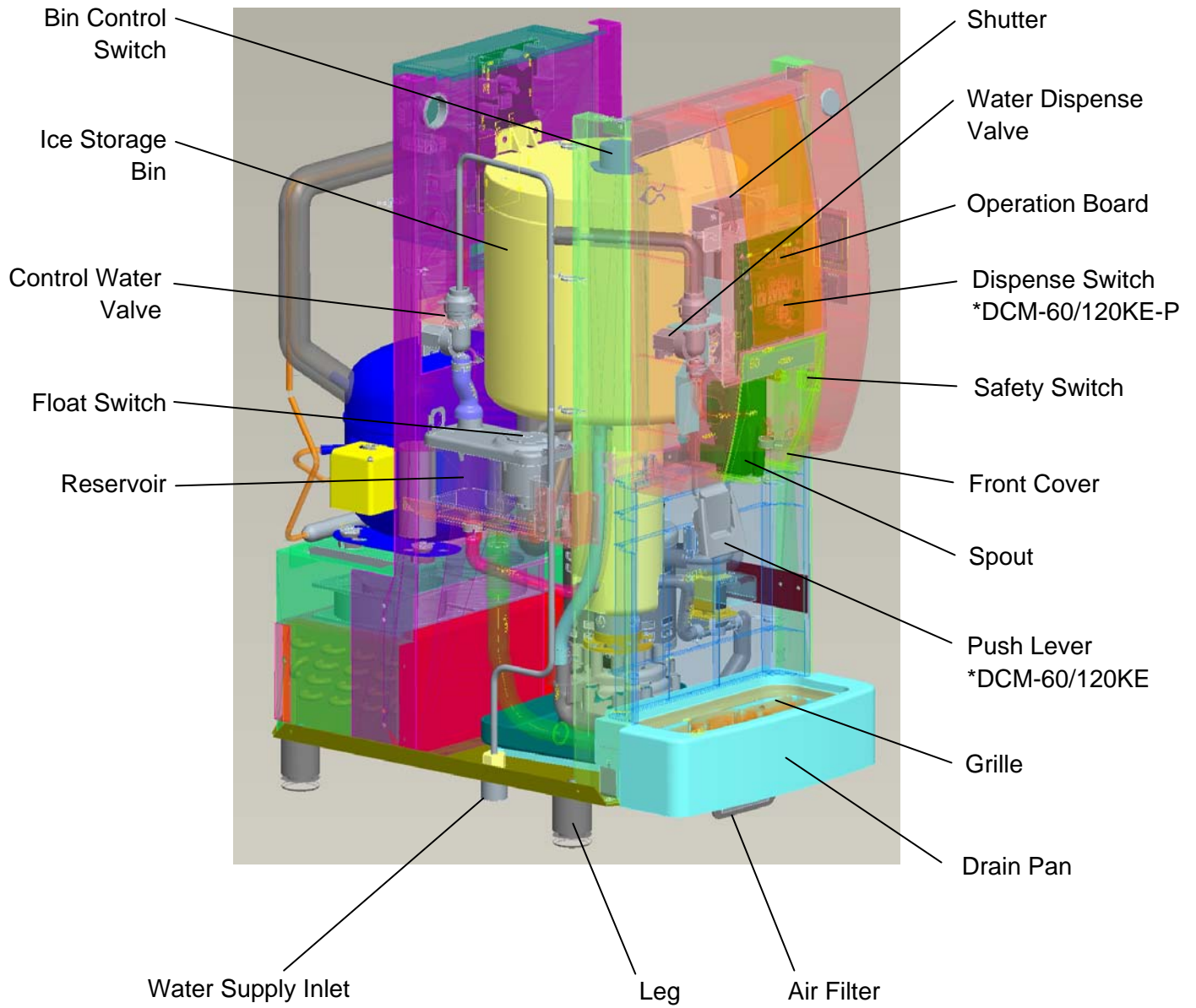

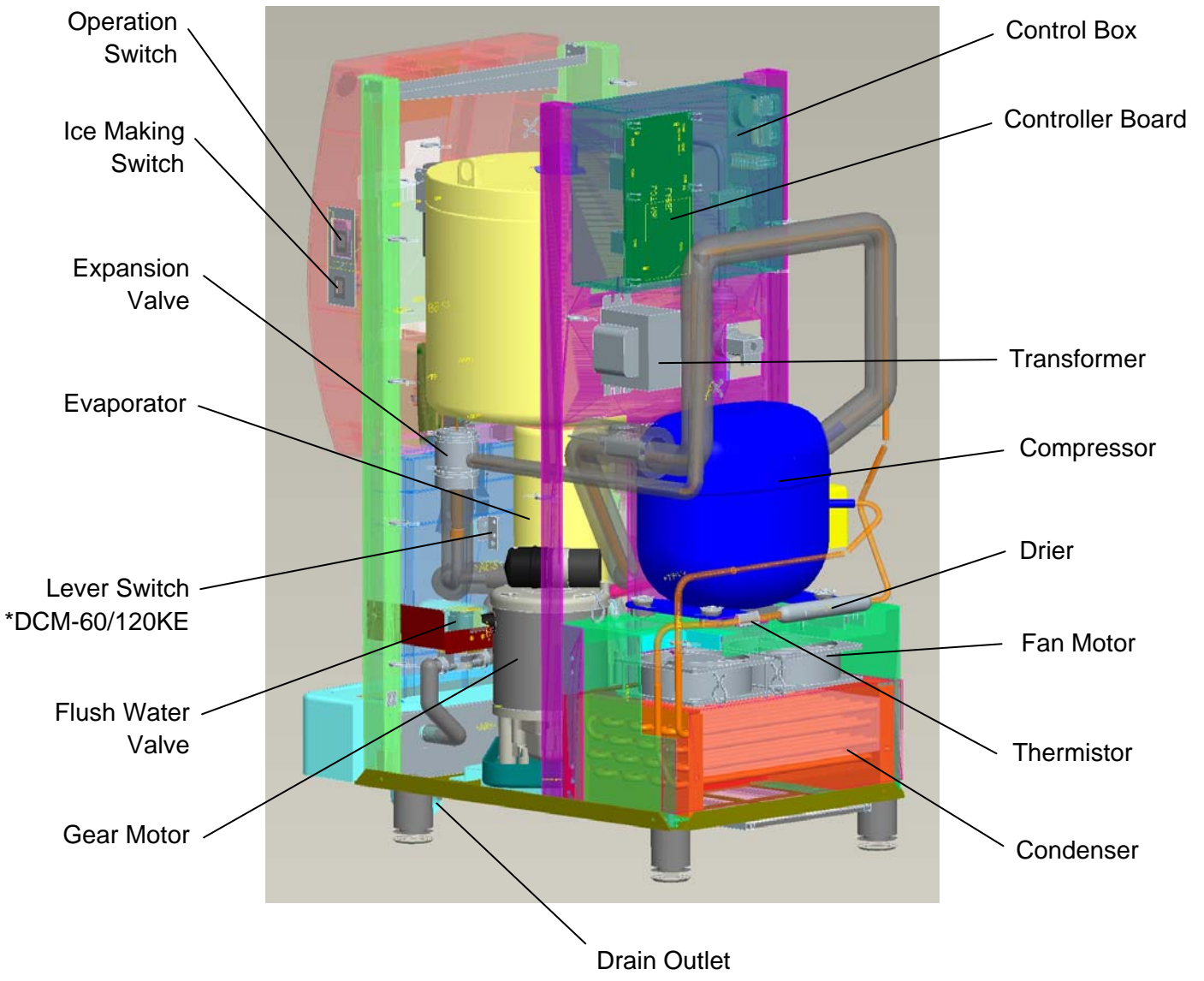

II. MAINTENANCE AND CLEANING INSTRUCTIONS

IMPORTANT

1. This ice dispenser must be maintained individually, referring to the instruction manual and labels provided with the ice dispenser.
2. To achieve optimum ice dispenser performance, the following parts need periodic inspection and maintenance:
 - Extruding head (upper bearing)
 - Housing (lower bearing)
 - Mechanical seal

These parts should be inspected after two years from installation or 10,000 hours of operation, whichever comes first, and once a year thereafter. Their service life, however, depends on water quality and environment. More frequent inspection and maintenance are recommended in bad or severe water conditions.

1. EXTRUDING HEAD (UPPER BEARING), HOUSING (LOWER BEARING)

These parts should be replaced if a diametrical gap of more than 0.5 mm is found when at least three spots are checked by changing the direction of the auger on each bearing.

It depends on the water quality and conditions, but normally the bearings should be checked for wear after a total of 8,000 - 10,000 hour operation from installation date.

Note: The clearance between the auger blades and the evaporator interior is 0.4 - 0.5 mm. If the bearings and rotating parts are worn out to create a larger clearance, the evaporator interior may be damaged. (The diameters differ by 0.8 - 1.0 mm.)

If the auger surfaces against which the bearings contact are no longer smooth or show any burrs or abrasions during the above inspection, replace the auger.

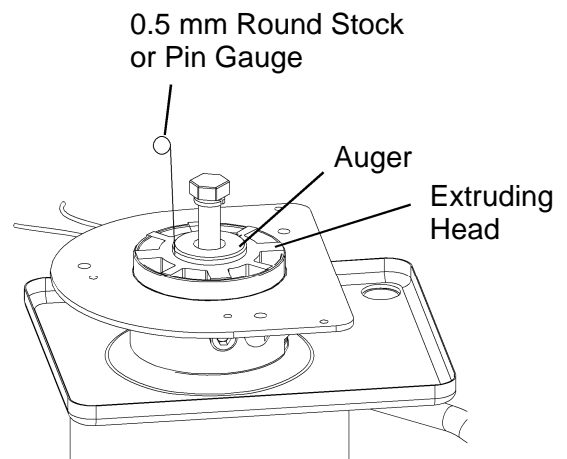

For reference only
(May differ from actual design)

2. MECHANICAL SEAL

The mechanical seal prevents water leaks from between the auger and the housing bearing and gradually wears out to reduce its watertightness. Check the amount of water leakage from the drain pipe located at the side of the gear case to determine the necessity of replacement.

<u>Total operation time</u>	<u>Water leakage</u>
3,000 hours	0.1 mL/h
10,000 hours	0.5 mL/h

Note: The water leakage will exceed the above amount with scale/dirt build up or damage on the mating surface. Replace the mechanical seal when the water leakage exceeds 0.5 mL/h.

3. GEAR MOTOR

After the following hours of operation, check the gear motor for excessive noise caused by increased torque or deterioration of mechanical parts.

Bearing, gear and other mechanical parts: 10,000 hours
Oil seal: 5 years

Note: When the output shaft oil seal is exposed to a large amount of water at one time, water may enter the gear case. Always drain the water circuit before removing the auger for service.

4. CONDENSER

Check the condenser once a year, and clean if required by using a brush or vacuum cleaner. More frequent cleaning may be required depending on the location of the ice dispenser.

5. AIR FILTER

Plastic mesh air filters remove dirt or dust from the air, and keep the condenser from getting clogged. If the filters get clogged, the ice dispenser's performance will be reduced. Remove and clean the air filter(s) at least twice per month:

- 1) Pull out the air filter from the bottom of the drain pan.
- 2) Clean the air filter by using a vacuum cleaner. When severely clogged, use warm water and a neutral cleaner to wash the air filter.
- 3) Rinse and dry the air filter thoroughly, and place it in position.

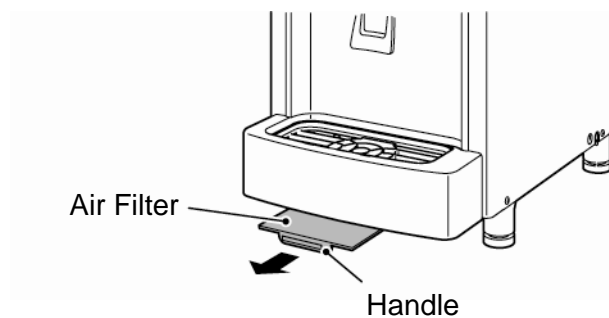

6. CONTROL WATER VALVE AND WATER DISPENSE VALVE

- 1) Unplug the ice dispenser.
- 2) Close the water supply tap.
- 3) Disconnect the fitting from the valve.
- 4) Clean the filter packing using a brush.
- 5) Replace the filter packing and fitting in their correct positions.
- 6) Open the water supply tap.
- 7) Plug in the ice dispenser.
- 8) Check for leaks.

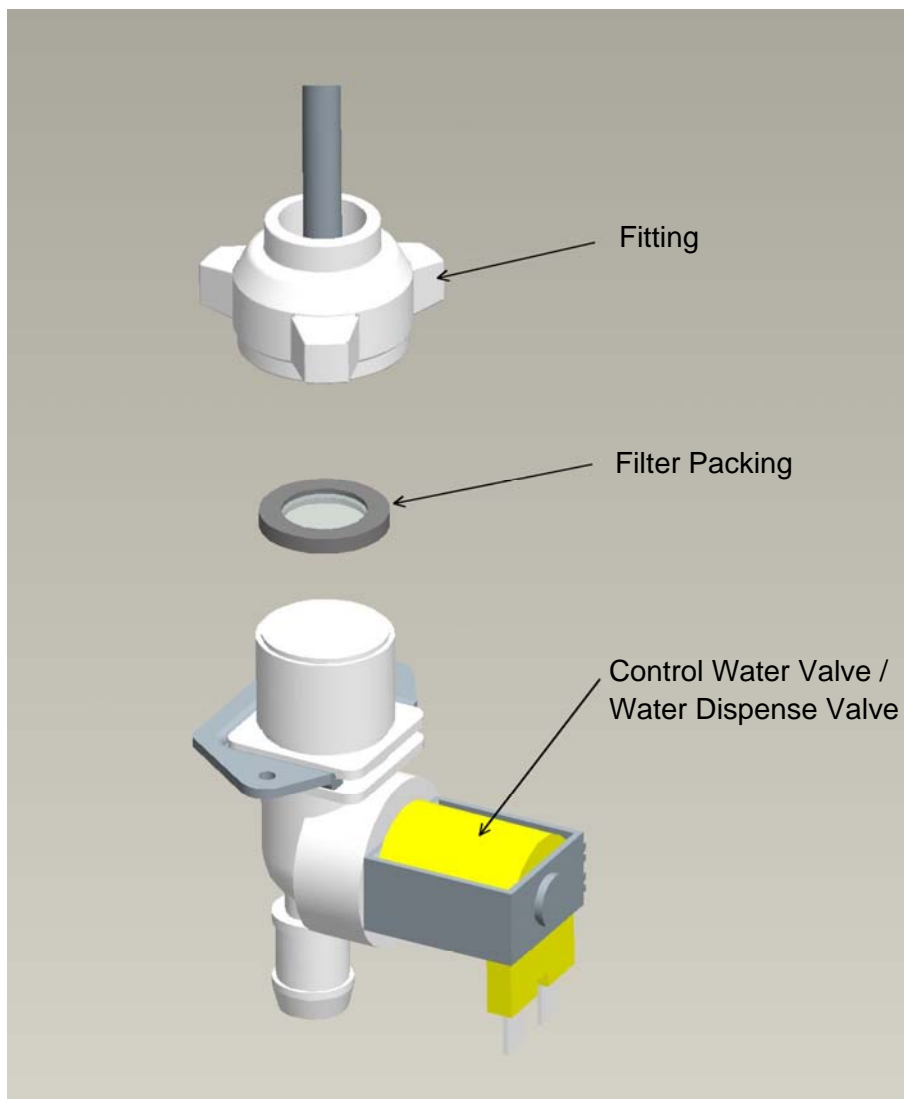

7. CLEANING OF WATER SYSTEM

WARNING

1. HOSHIZAKI recommends cleaning this unit at least twice a year. More frequent cleaning, however, may be required in some existing water conditions.
2. Do not touch the operation switch and ice making switch with damp hands.
3. Always wear rubber gloves, eye protectors, apron, etc. for safe handling of the cleaner and sanitiser.
4. Use the cleaners and sanitisers recommended by Hoshizaki. Contact your local Hoshizaki office for further details. (The instructions below give an example of those recommended cleaners and sanitisers.)
5. Never mix cleaning and sanitising solutions in an attempt to shorten cleaning time.
6. Wipe off any splashed or spilt cleaner/sanitiser immediately.
7. Do not use any ammonia type cleaners on any part of the ice dispenser.

CAUTION

Do not use ice produced with cleaning and sanitising solutions. Be sure none remains in the storage bin on completion of cleaning.

<STEP 1>

Dilute the solutions with water as follows:

Cleaning solution: "Nickel-Safe Ice Machine Cleaner" by The Rectorseal Corporation or similar. Prepare approximately 5 L of solution as directed on the container.

Sanitising solution: 30 mL of 5.25% sodium hypochlorite with 7.6 L of water or the Hoshizaki recommended sanitiser as directed on the container.

IMPORTANT

For safety and maximum effectiveness, use the solutions immediately after dilution.

<STEP 2>

Use the cleaning solution to remove lime deposits in the water system.

- 1) Move the ice making switch to the "OFF" position.
- 2) Press the push lever or dispense switch to dispense ice, and remove all ice from the storage bin.

- 3) Press the drain switch on the control panel. The display illuminates "DRAIN" during the 1 minute drain cycle.
- 4) Unplug the ice dispenser.
- 5) Remove the top panel and storage bin cover.
- 6) Pour the cleaning solution carefully into the opening in the center of the storage bin (top of the evaporator) to an overflow level (surplus solution will be seen overflowing into the drain pan).

Note: The overflow will be from the water reservoir and indicates that it is full.

- 7) Allow the cleaning solution to stand for 10 minutes. During this time, take a small brush or a cloth and clean the inside of the storage bin with the remaining solution.
- 8) Refit the storage bin cover, and loosely fit the machine's top panel.
- 9) Plug in the ice dispenser to make ice with the cleaning solution.
- 10) With the water supply tap open, move the ice making switch to the "ON" position. Allow the machine to continue ice making for a further 20 minutes.
- 11) Move the ice making switch to the "OFF" position.
- 12) Press the drain switch on the control panel.
- 13) While the display illuminates "DRAIN" during the 1 minute drain cycle, pour warm water into the storage bin to melt any ice down the drain.

Note: 1. If the machine has heavy deposits of scale, repeat the complete cleaning procedure.

2. Do not increase the proportion of cleaning solution to shorten cleaning times, as this may lock the auger when completing item 7).

<STEP 3>

Note: Sanitising should always be completed after cleaning or alternately as an individual procedure if conditions exist to make it necessary.

Use 2.8 litres of the sanitising solution to sanitise the ice dispenser.

- 14) Unplug the ice dispenser.
- 15) Remove the top panel and storage bin cover.
- 16) Pour the sanitising solution carefully into the reservoir through the opening in the center of the storage bin up to an overflow level.

- 17) Wait for 10 minutes. During this time, use a clean cloth and some of the remaining solution to wipe the inside of the storage bin and the bin cover. (Do not fit the agitator or the drip ring.)
- 18) Refit the storage bin cover, and loosely fit the machine's top panel.
- 19) Plug in the ice dispenser to make ice with the sanitising solution.
- 20) With the water supply tap open, move the ice making switch to the "ON" position. Allow the machine to continue ice making for a further 20 minutes.
- 21) Move the ice making switch to the "OFF" position.
- 22) Press the drain switch on the control panel.
- 23) While the display illuminates "DRAIN" during the 1 minute drain cycle, pour clean warm water carefully into the bin to melt any ice and into the opening in the center to an overflow level. Be careful not to wet the bin control switch on the storage bin cover.
- 24) Unplug the ice dispenser.
- 25) Remove the top panel and storage bin cover.
- 26) Remove the agitator by unscrewing counterclockwise. Lift out the drip ring.
- 27) Take a clean cloth and a pan of fresh cold water to wipe/rinse thoroughly the bin liner and storage bin cover.
- 28) Wash the agitator and drip ring with a neutral cleaner. Rinse thoroughly.
- 29) Immerse the agitator and drip ring into the remaining sanitising solution. Rinse thoroughly.
- 30) Refit the removed parts in reverse order.

III. TECHNICAL INFORMATION

1. WATER CIRCUIT AND REFRIGERANT CIRCUIT

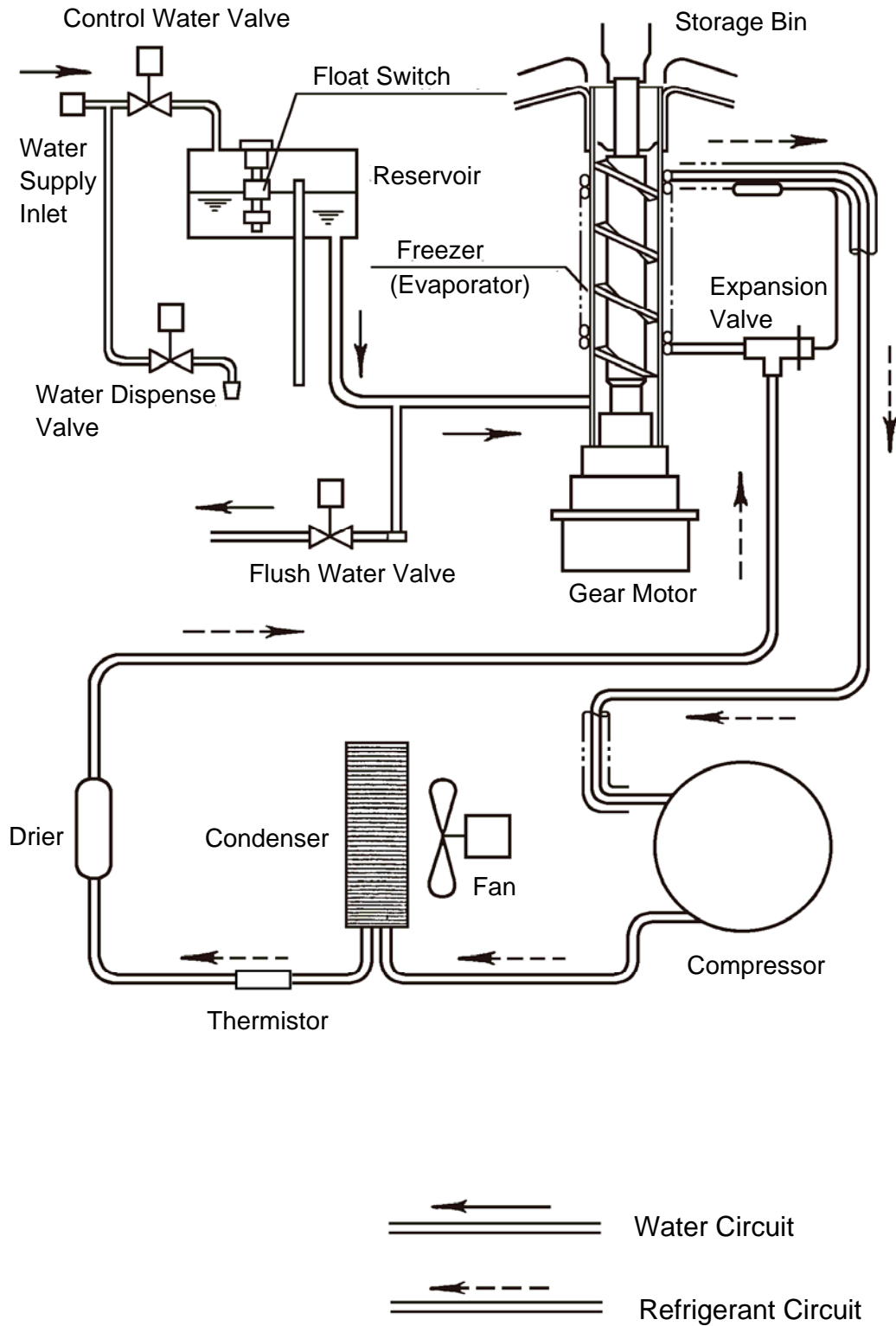

2. WIRING DIAGRAM

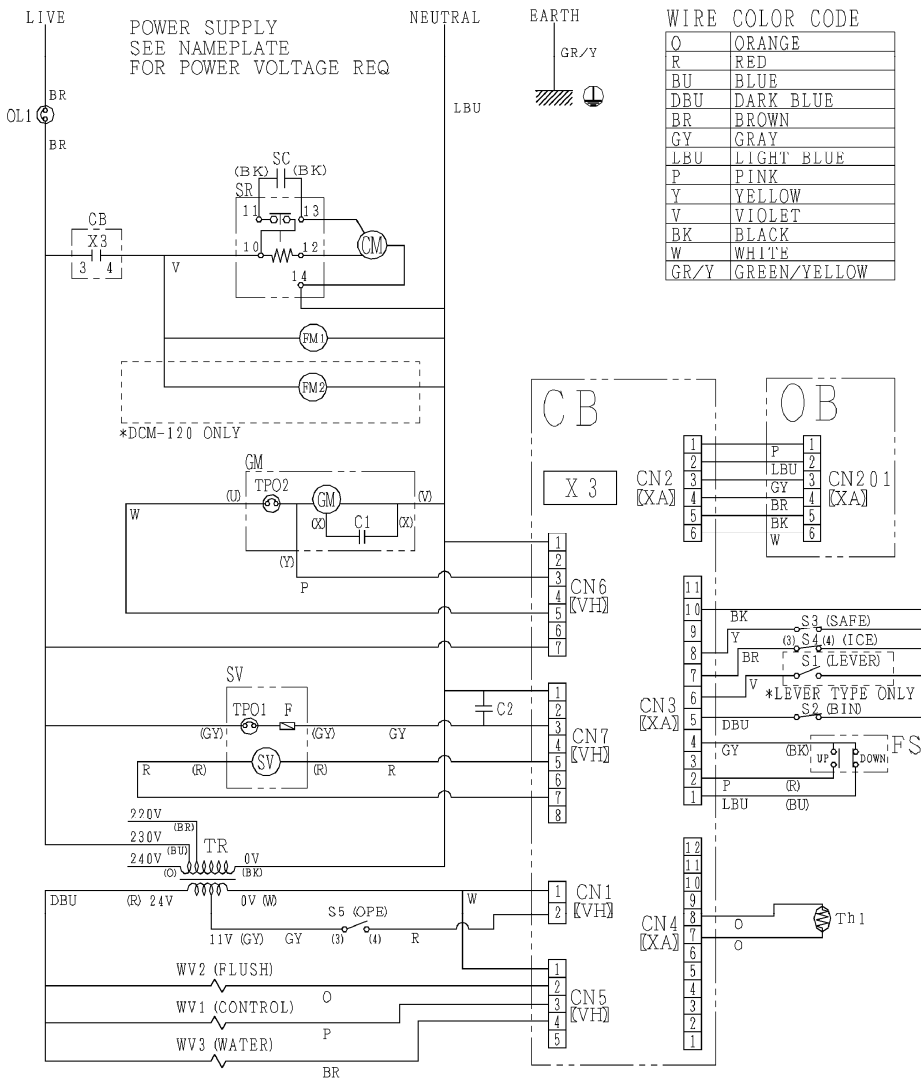

ERROR TABLE

E0	ICEMAKING WATER LEAK
C0	
E1	LOW ICE PRODUCTION
C8	
E2	FLOAT SWITCH ERROR
E3	
EE	GEAR MOTOR ERROR
C5	
E4	ABNORMAL HIGH SIDE PRESSURE
C2	
E5	GEAR MOTOR DRIVE ELEMENT ERROR
Eb	CONDENSER OUTLET THERMISTOR CIRCUIT OPEN
Ed	OPERATION BOARD COMMUNICATION ERROR
EF	
C3	ABNORMAL LOW VOLTAGE
EL	BIN CONTROL SWITCH ERROR
EP	MODEL SETTING NO. ERROR
EU	CONTROLLER BOARD ERROR
C1	LOW WATER
C4	DRAIN ERROR

PART NAME

CB	CONTROLLER BOARD
OB	OPERATION BOARD
X3	POWER RELAY (COMPRESSOR, ON BOARD)
CM	COMPRESSOR
OL1	CIRCUIT PROTECTOR (10A)
SC	STARTING CAPACITOR (CM)
SR	STARTER (CM)
SV	SOLENOID
TPO1	THERMAL PROTECTOR (SV)
F1	FUSE (SV)
GM	GEAR MOTOR
C1	CAPACITOR (GM)
TPO2	THERMAL PROTECTOR (GM)
FM1	FAN MOTOR
FM2	FAN MOTOR (ONLY DCM-120)
TR	TRANSFORMER
S1	LEVER SWITCH (ONLY LEVER TYPE)
S2	BIN CONTROL SWITCH
S3	SAFETY SWITCH
S4	ICE MAKING SWITCH
S5	OPERATION SWITCH
FS	FLOAT SWITCH
WV1	CONTROL WATER VALVE
WV2	FLUSH WATER VALVE
WV3	WATER DISPENSE VALVE
C2	CAPACITOR (NOISE FILTER)
Th1	THERMISTOR (CONDENSER OUTLET)

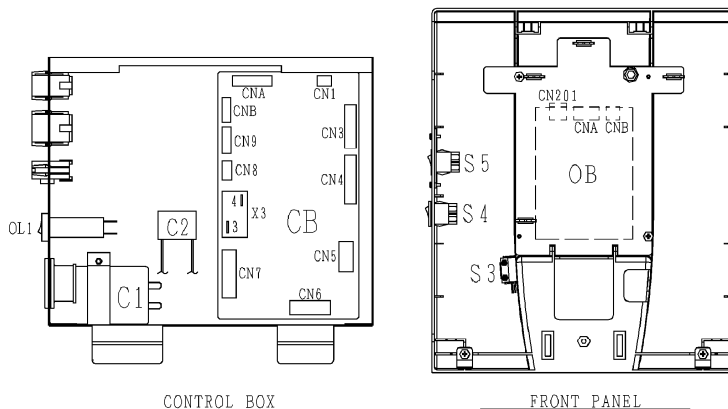

3. ICEMAKING MECHANISM

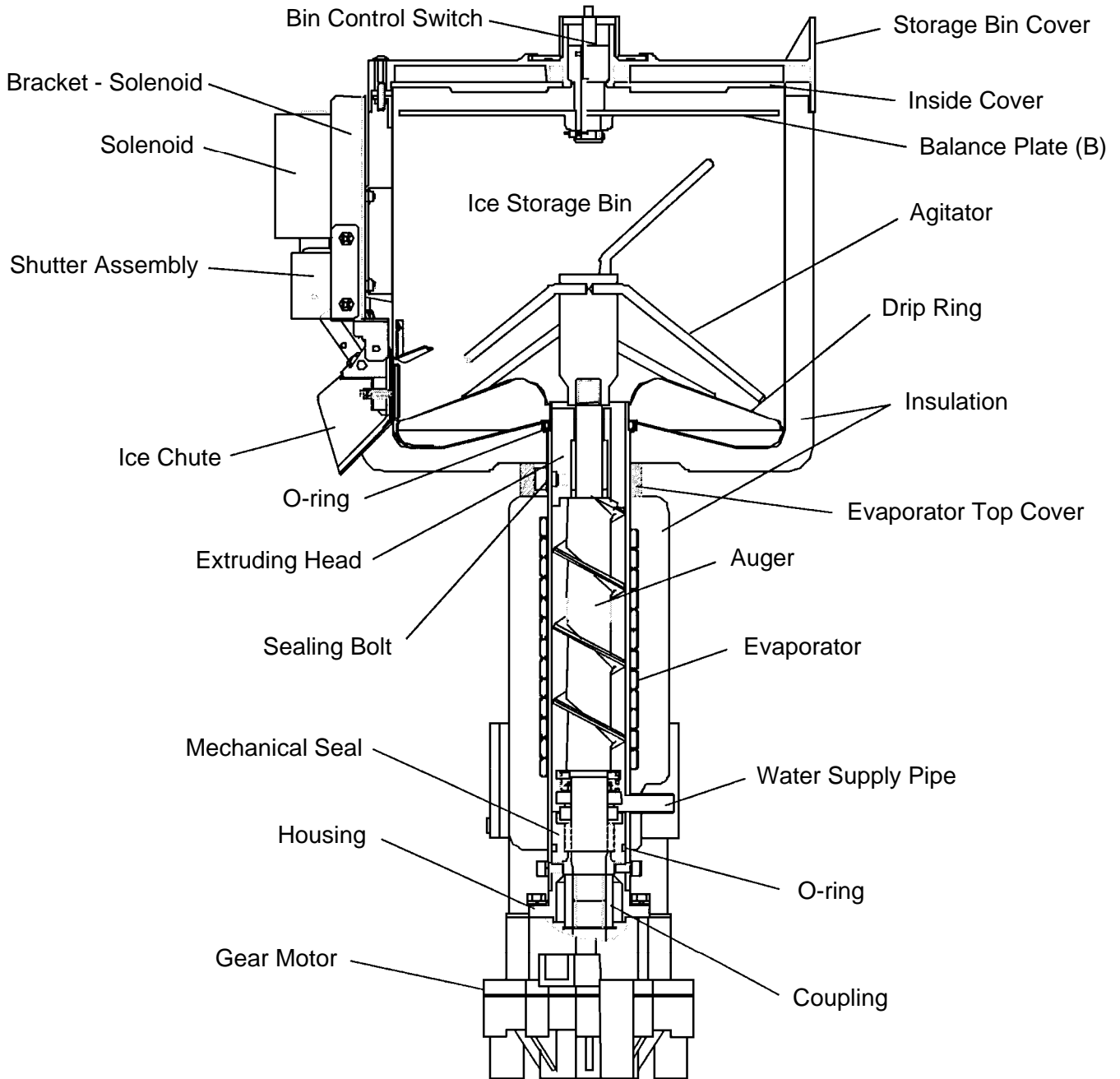

[a] EVAPORATOR (CASING)

The evaporator consists of a stainless steel icemaking cylinder coiled with a refrigeration pipe and wrapped together with a polyurethane foam insulation material. Water coming from the inlet into the evaporator will be frozen into ice. The ice spout is located on top of the evaporator.

[b] AUGER

The stainless steel auger is supported by the upper and lower bearings of the evaporator and slowly rotated by the gear motor, while scraping off the ice forming on the inner wall of the cylinder and pushing up to the ice spout.

[c] EXTRUDING HEAD (BEARING)

The stainless steel extruding head is provided with a press-fit plastic bearing inside and fixed on top of the evaporator. The extruding head functions as the auger bearing and compresses the sherbet ice carried up by the auger into a column shape with the path resistance.

[d] HOUSING

The cast bronze housing is provided with a press-fit plastic bearing inside and fixed on the bottom of the evaporator for connection with the gear motor.

[e] MECHANICAL SEAL

The mechanical seal on the lower auger bearing prevents icemaking water leaks into the evaporator. The mating surfaces are made of ceramic and carbon.

[f] COUPLING (SPLINE JOINT)

The auger bottom and gear motor output shaft are splined and connected with the spline joint.

[g] GEAR MOTOR

The gear motor consists of a 200W 1 phase 240V or 80W 1 phase 220 - 240 / 220V drive motor integrated with a decelerator and provided with a built-in auto-reset thermal protector. When the thermal protector trips, the controller board will stop the gear motor. The thermal protector trips when the gear motor mechanism is overloaded or when excessively high or low voltage is applied on the gear motor. The electrical capacity must be increased if a large current flows through the surrounding equipment.

[h] SEALING BOLT

Sometimes the icemaking operation may produce white solids on the drip pan. They are deposits of silica and calcium contents in the icemaking water leaking from the sealing bolt. The bolt is provided with retaining and sealing functions, which may be reduced by the load and vibration during a freeze cycle. Do not reuse a removed sealing bolt.

Solids deposited from
sealing bolt



4. ELECTRIC CIRCUIT

CAUTION

Reassemble all the components as they were after servicing the unit according to a service call.

[a] BASIC OPERATION

The ice dispenser starts water supply when the operation switch and ice making switch are moved to the "ON" position. On completion of water supply, the gear motor starts immediately. After 5 minutes the compressor starts to begin icemaking operation.

In normal operation, the ice dispenser shuts down when the storage bin fills up to trip the bin control switch or the ice making switch is moved to the "OFF" position.

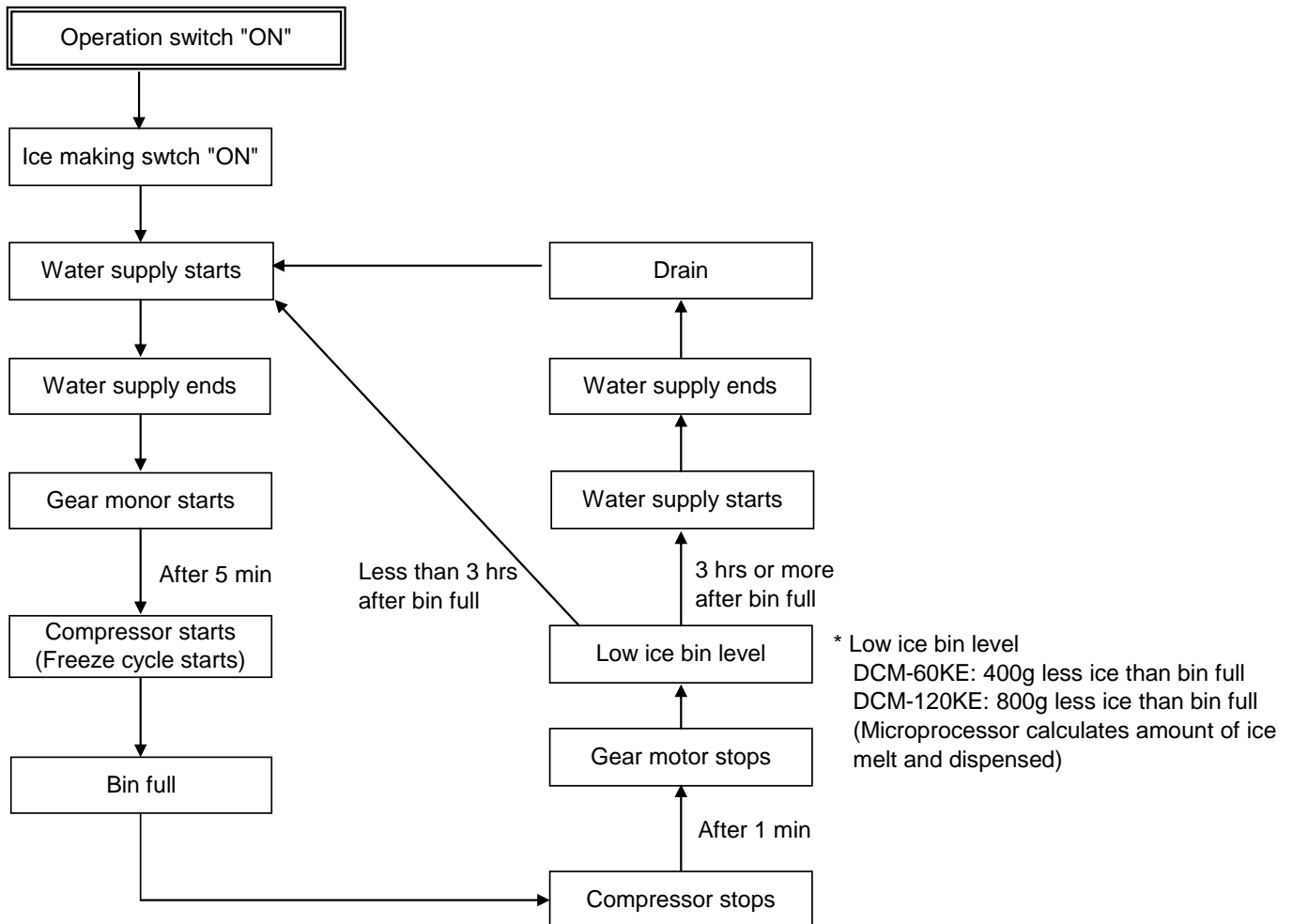

[b] TIMING CHART

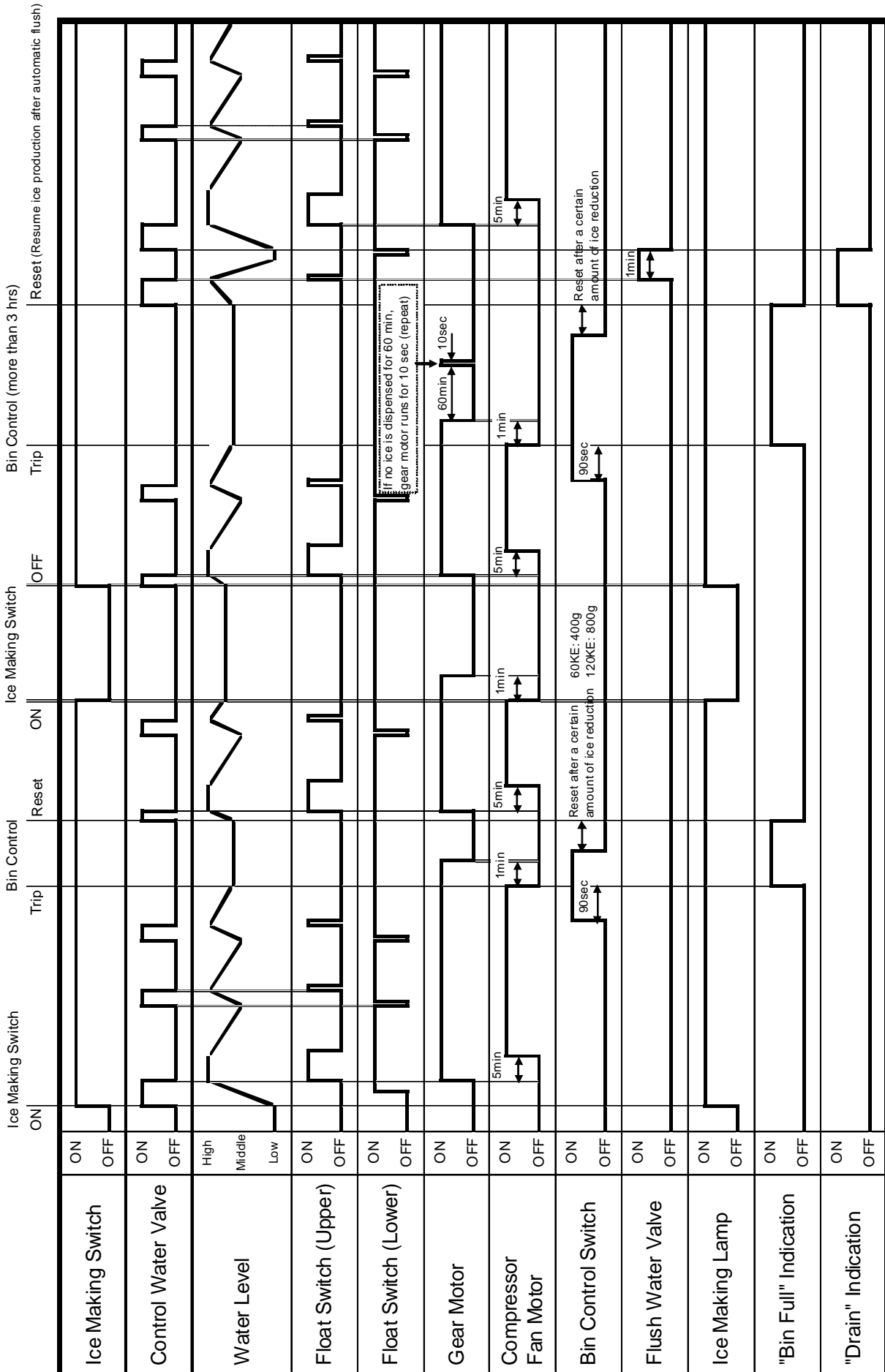

5. OPERATION BOARD

[a] DISPLAYING COMPRESSOR OPERATING HOURS

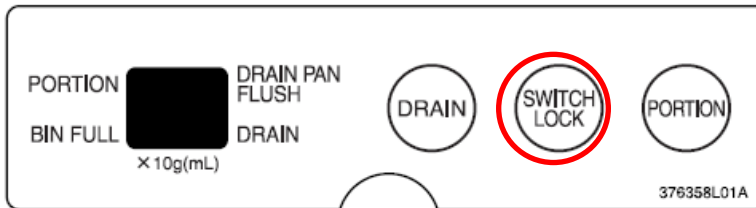

- 1) Press and hold the lock switch.
- 2) After 3 seconds, the display shows the compressor operating hours.

Note: The display shows the compressor operating hours in six digits divided into three parts (two digits for 2 seconds each time).

Then, “- -” appears in the display (to show the end of the compressor operating hours display mode).

e.g. 3527 hours = “00”, “35”, “27”, “- -”

[b] DISPLAYING CYCLE TIME

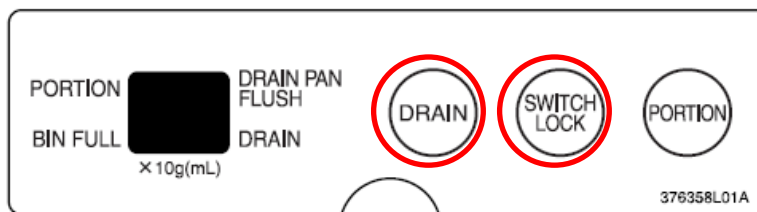

- 1) Press and hold the lock switch.
- 2) After 3 seconds, the display shows the compressor operating hours.
- 3) While still holding down the lock switch, press the drain switch once.
- 4) The display shows the cycle time.

Note: The display shows the cycle time in four digits divided into two parts (first minutes then seconds, for 2 seconds each time) from the latest record (5 records at maximum).

Then, “- -” appears in the display (to show the end of the cycle time display mode).

If no cycle time is recorded, the display shows “- -” only.

Minutes are indicated as follows:

0	0 to 9	= 0 to 9 minutes
A	0 to 9	= 10 to 19 minutes
b	0 to 9	= 20 to 29 minutes
C	0 to 9	= 30 to 39 minutes
d	0 to 9	= 40 to 49 minutes
E	0 to 9	= 50 to 59 minutes

Seconds are indicated as

0 to 5

0 to 9

.

e.g.

09

48

 = 9 minutes 48 seconds

b7

36

 = 27 minutes 36 seconds

By using the freeze cycle time, **approximate ice production capacity** can be calculated.

Ice production capacity (kg/d) = 24,000 / cycle time (sec)

* If the automatic drain pan flush is activated, the cycle time becomes longer because the drain pan is flushed at the same time as water is supplied to the reservoir.

[c] DISPLAYING MODEL NUMBER



- 1) Press and hold the lock switch.
- 2) After 3 seconds, the display shows the compressor operating hours.
- 3) While still holding down the lock switch, press the drain switch twice.
- 4) The display shows the model number.

Note: The display shows two digits.

* The model number is specified on the wiring label.

[d] SETTING MODEL NUMBER

The model number setting is required at the time of replacement of the controller board (not required at the time of replacement of the operation board only). Without this setting, the ice dispenser will display “EP” and will not work. Check the model number specified on the wiring label. Improper setting may result in failure or inoperability. Check for the correct model number after this setting.

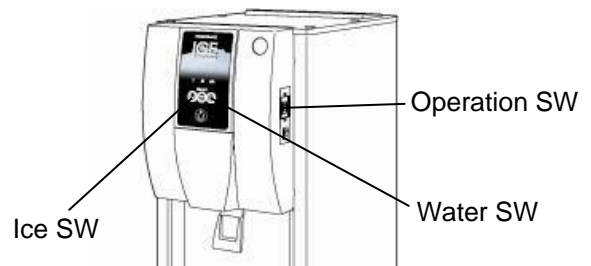
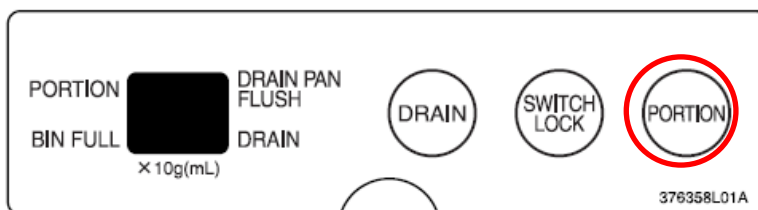

- 1) Press and hold the portion control switch, and turn on the operation switch.
- 2) The display shows current model number, and the water switch and ice switch flash.
- 3) Press the water switch to increase the number, or press the ice switch to decrease the number until it matches the model number on the wiring label.
- 4) Press the portion control switch to complete the setting.

[e] DISPLAYING CONTROLLER BOARD SOFTWARE VERSION

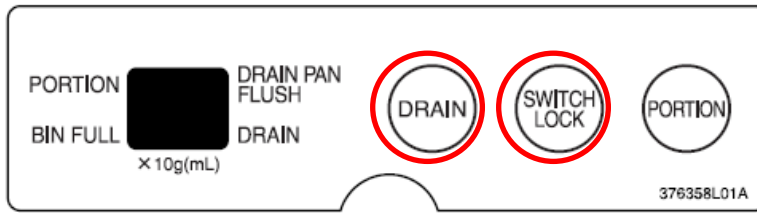

- 1) Press and hold the lock switch.
- 2) After 3 seconds, the display shows the compressor operating hours.
- 3) While still holding down the lock switch, press the drain switch three times.
- 4) The display shows the software version of controller board.

Note: The display shows the software version divided in three parts.
e.g. Ver. 1-1-1 = "1", "-1", "-1"

[f] DISPLAYING OPERATION BOARD SOFTWARE VERSION

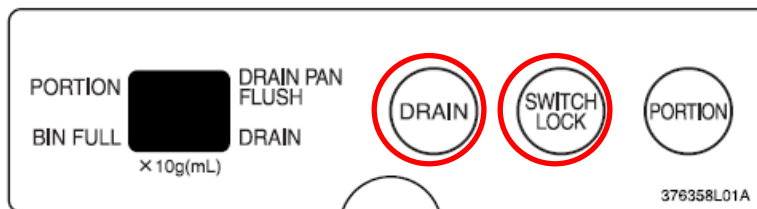

- 1) Press and hold the lock switch.
- 2) After 3 seconds, the display shows the compressor operating hours.
- 3) While still holding down the lock switch, press the drain switch four times.
- 4) The display shows the software version of operation board.

Note: The display shows the software version divided in three parts.
e.g. Ver. 1-0-0 = "1", "-0", "-0"

[g] DISPLAYING ERROR LOG AND ONGOING ERROR

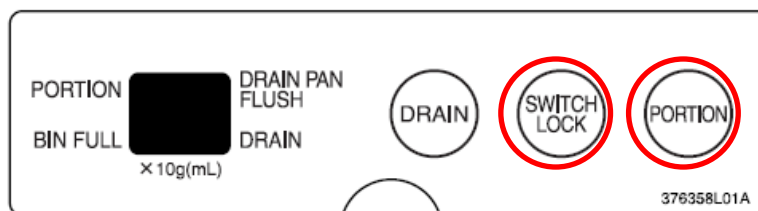

- 1) Press and hold the lock switch.
- 2) After 3 seconds, the display shows the compressor operating hours.
- 3) While still holding down the lock switch, press the portion control switch once.
- 4) The display shows error log.
- 5) When the display shows "- -" to indicate the end of the error log display mode, press the portion control switch once.

6) The display shows ongoing error.

- Note:
1. The display shows up to eight errors from the latest error.
 2. If there is no error log, the display shows “- -”.
 3. Ongoing errors appear from the smallest error code, not from the latest error.

[h] RESETTING ERROR LOG

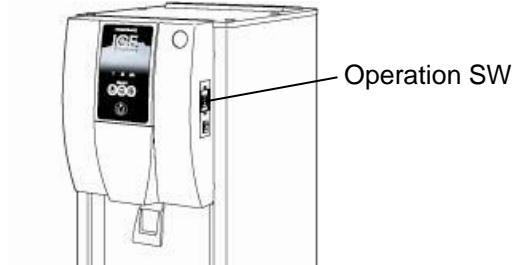
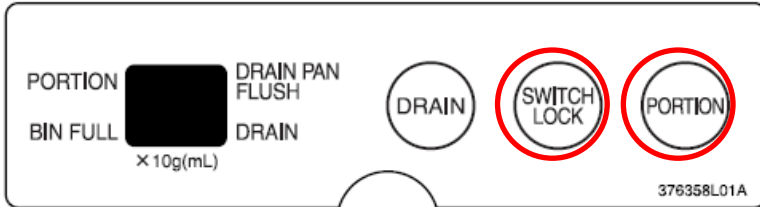

- 1) Press and hold the lock switch and portion control switch together, and turn on the operation switch.
- 2) Error log is reset.

[i] REDUCING COMPRESSOR STARTING TIME

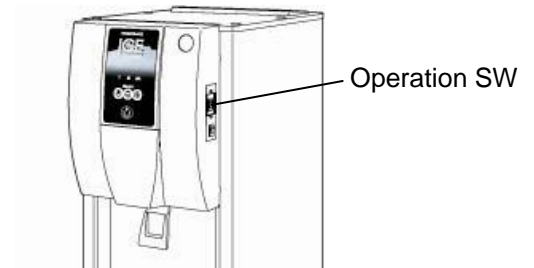

- 1) Press and hold the lock switch, and turn on the operation switch.
- 2) The display shows the model number, and the compressor starts running.

Note: The compressor startup delay time is reduced from 5 minutes to 2 minutes.

[j] RESETTING COMPRESSOR OPERATING HOURS

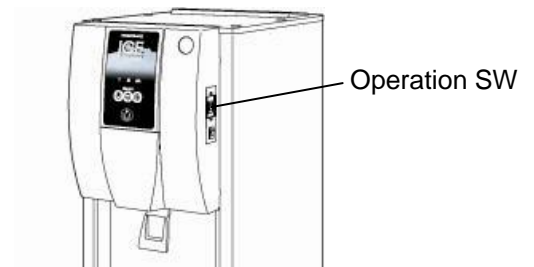
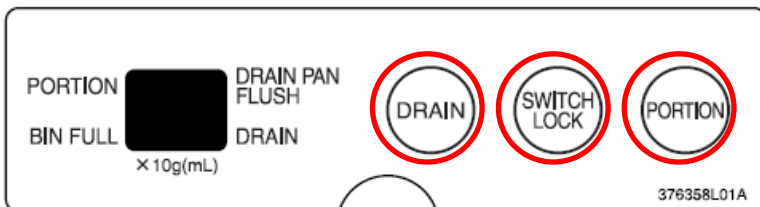

- 1) Press and hold the drain switch, lock switch and portion control switch together, and turn on the operation switch.
- 2) The display shows “FA” and then the model number.
- 3) The compressor operating hours are reset.
- 4) Turn off the operation switch.

Note: Be sure to turn off the operation switch once, otherwise malfunction may occur.

6. ERROR CODES

Interlock Errors

Code	Error	Condition	Operation	Reset	Check/Repair
E0	Icemaking Water Leak	c0 error occurs 2 times in a row.	Service call lamp blinks. E0 blinks. Whole unit stops. Dispensing not available.	Power supply, Turn OFF - Turn ON	Water leak from water circuit (reservoir, inlet hose, outlet hose, hose joint, mechanical seal, flush water valve), float switch
E1	Low Ice Production	c8 error occurs 2 times in a row.	Service call lamp blinks. E1 blinks. Whole unit stops. Dispensing not available.	Power supply, Turn OFF - Turn ON	Gas leak, control water valve not closing, vapor lock, freeze, float switch, bin control switch
E2	Float Switch Error	With flush water valve OFF, float switch trips at both upper and lower float levels for 2 seconds.	Service call lamp blinks. E2 blinks. Whole unit stops. Dispensing not available.	Power supply, Turn OFF - Turn ON	Float switch
E3	Gear Motor Error	Gear motor relay is ON with gear motor protective circuit detector OFF.	Service call lamp blinks. E3 blinks. Whole unit stops. Dispensing not available.	Power supply, Turn OFF - Turn ON	Gear motor protective circuit (TPO, overload, etc.), gear motor relay
E4	Abnormal High Side Pressure	c2 error occurs 5 times in 1 hour of compressor operation.	E4 blinks.	N/A	Fan motor, refrigeration circuit, condenser clogged, installation conditions
E5	Gear Motor Drive Element Error	Gear motor relay is OFF with gear motor protective circuit detector ON.	Service call lamp blinks. E5 blinks. Whole unit stops. Dispensing not available.	Power supply, Turn OFF - Turn ON	Miswiring, gear motor relay Replace controller board.
Eb	Condenser Thermistor Circuit Open	Condenser thermistor circuit is open.	Service call lamp blinks. Eb blinks. Whole unit stops. Dispensing not available.	Power supply, Turn OFF - Turn ON	Condenser thermistor
Ed	Operation Board Communication Error	Operation board fails to communicate with controller board for more than 1 second.	Service call lamp blinks. Whole unit stops. Dispensing not available	Power supply, Turn OFF - Turn ON	Controller board, operation board, communication line between operation board and controller board
EE	Gear Motor Error	c5 error occurs 5 times.	Service call lamp blinks. EE blinks. Whole unit stops. Dispensing not available	Power supply, Turn OFF - Turn ON	Gear motor locked, hunting or overloaded, supply voltage, high ambient temperature

Code	Error	Condition	Operation	Reset	Check/Repair
EF	Abnormal Low Voltage	c3 error occurs 3 times in 24 hours.	Service call lamp blinks. EF blinks. Whole unit stops. Dispensing not available	Power supply, Turn OFF - Turn ON	Supply voltage
EL	Bin Control Switch Error	While compressor is running, number of water supply cycles reaches in a row: DCM-60KE(-P) 12 times DCM-120KE(-P) 24 times * This count is reset when ice is dispensed or compressor stops.	Service call lamp blinks. EL blinks. Whole unit stops. Dispensing not available	Power supply, Turn OFF - Turn ON	Bin control switch
EP	Model Setting No. Error	Controller board model number is not set.	Service call lamp blinks. EP blinks. Whole unit stops. Dispensing not available	Power supply, Turn OFF - Turn ON	Controller board model setting
EU	Controller Board Error	Controller board IC fails.	Service call lamp blinks. EU blinks. Whole unit stops. Dispensing not available	Power supply, Turn OFF - Turn ON	Replace controller board.
None	Electric Leak Short Circuit	Electric leak or overcurrent.	Service call lamp blinks. Whole unit stops. Dispensing not available	Power supply, Turn OFF - Turn ON	Electric leak, fuse

Non-Interlock Errors

Code	Error	Condition	Operation	Reset	Check/Repair
CM Time “- -”	Microcomputer Read/Write Error	Microcomputer fails to read/write properly.	Memory circuit not available.	Replace controller board.	Error records and compressor operating hours not available on display
c0	Icemaking Water Leak	After initial water supply, float switch trips at lower float level within 5 minutes after gear motor starts and before compressor starts.	Whole unit stops. Flush water valve turns ON for 1 second, then turns OFF. Unit restarts.	Error record only.	Water leak from water circuit (reservoir, hoses, mechanical seal, flush water valve), float switch
c1	Low Water	Water supply continues for more than 90 seconds, or float switch trips at lower float level and does not reset for more than 60 seconds after water supply.	Ice making lamp blinks. Whole unit stops. Dispensing is not available until reservoir fills up. Only control water valve operates intermittently for 5 minutes.	Automatically resets after reservoir fills up.	Water supply interruption, control water valve not opening, flush water valve not closing, float switch, water leak

Code	Error	Condition	Operation	Reset	Check/Repair
c2	Abnormal High Side Pressure	Condenser thermistor reads higher than set point for 5 seconds.	Ice making lamp blinks. Whole unit stops. Dispensing not available.	Automatically resets after pressure switch turns ON or condenser outlet thermistor reads lower than set point.	Fan motor, refrigeration circuit, condenser clogged, installation conditions
c3	Abnormal Low Voltage	Voltage stays below setting for more than 1 second. * For 15 seconds after compressor starts, abnormal low voltage is not detected.	Ice making lamp blinks. Whole unit stops. Dispensing not available.	Automatically resets after voltage stays above reset setting for 2 minutes.	Supply voltage
c4	Drain Error	After drain cycle, float switch trips at lower float level and upper float level (reservoir full).	N/A	Error record only.	Flush water valve not opening, control water valve not closing
c5	Gear Motor Error	While gear motor is running (at least 10 seconds after gear motor starts), voltage detection signal is not input to controller board.	Ice making lamp blinks. Whole unit stops. Dispensing not available.	Automatically resets after 30 minutes.	Gear motor locked, hunting or overloaded, supply voltage, high ambient temperature
c8	Low Ice Production	Interval between reservoir water supplies exceeds: DCM-60KE(-P) 1st freeze cycle 40 minutes 2nd cycle or later 20 minutes DCM-120KE(-P) 1st freeze cycle 30 minutes 2nd cycle or later 15 minutes	Whole unit stops, then automatically restarts.	Error record only.	Water leak from water circuit (reservoir, inlet hose, outlet hose, hose joint, mechanical seal, flush water valve), float switch

7. PERFORMANCE DATA

[a] DCM-60KE(-P): 50Hz

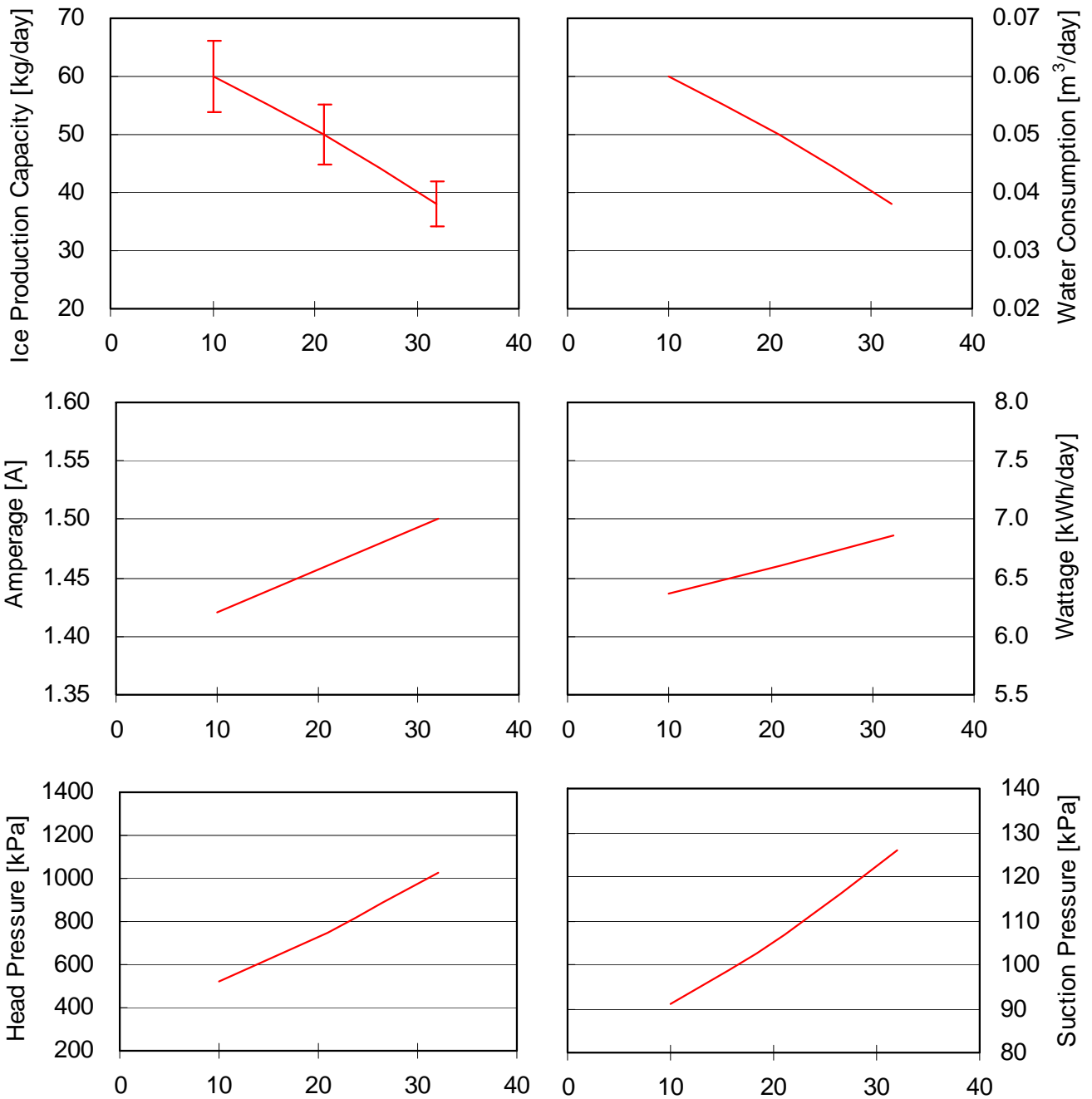

The horizontal axis shows the ambient temperature
 It refers to data of at/wt=10/10, 21/15, 32/21

[b] DCM-60KE(-P): 60Hz

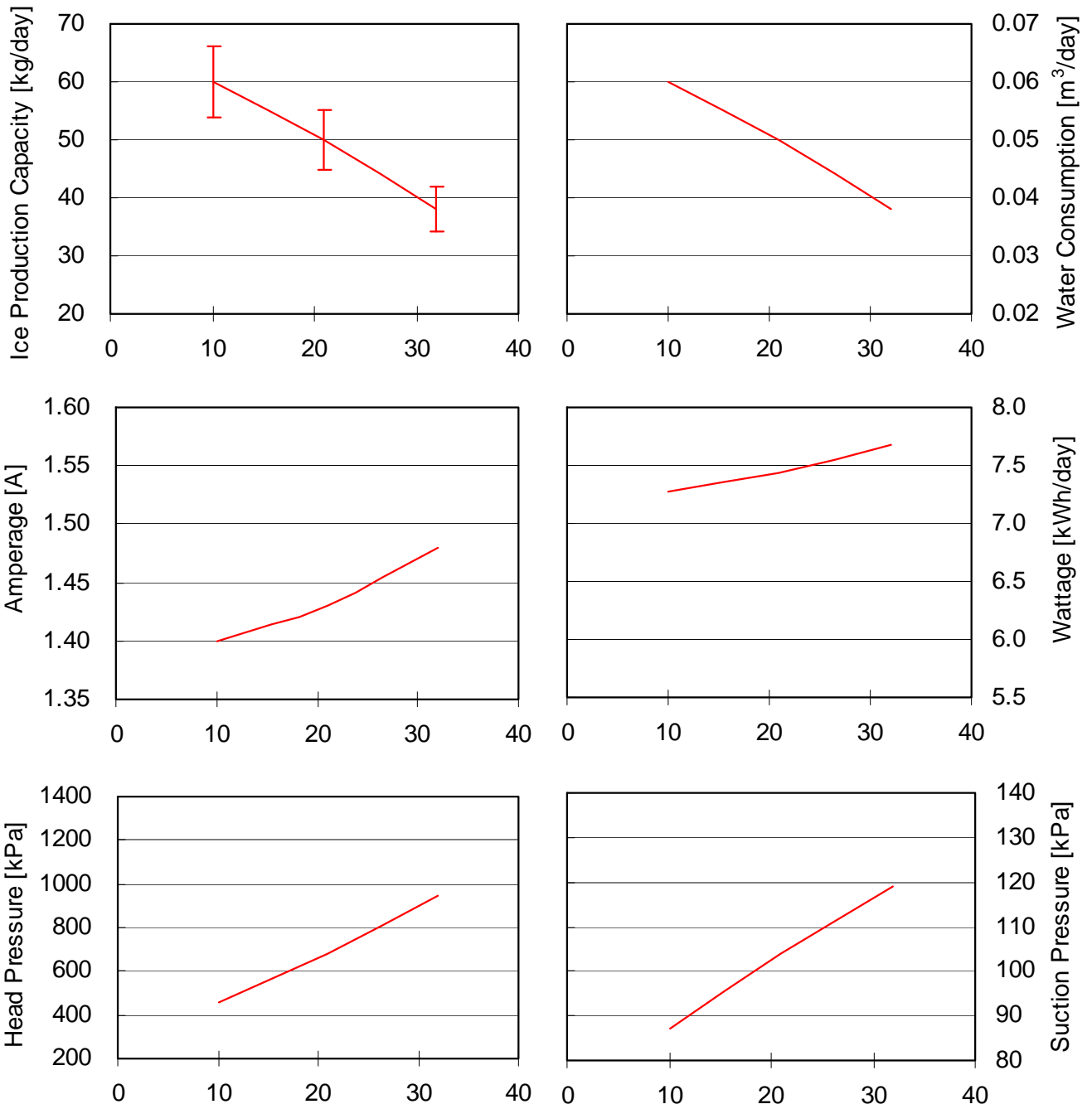

The horizontal axis shows the ambient temperature
 It refers to data of at/wt=10/10, 21/15, 32/21

[c] DCM-120KE(-P): 50Hz

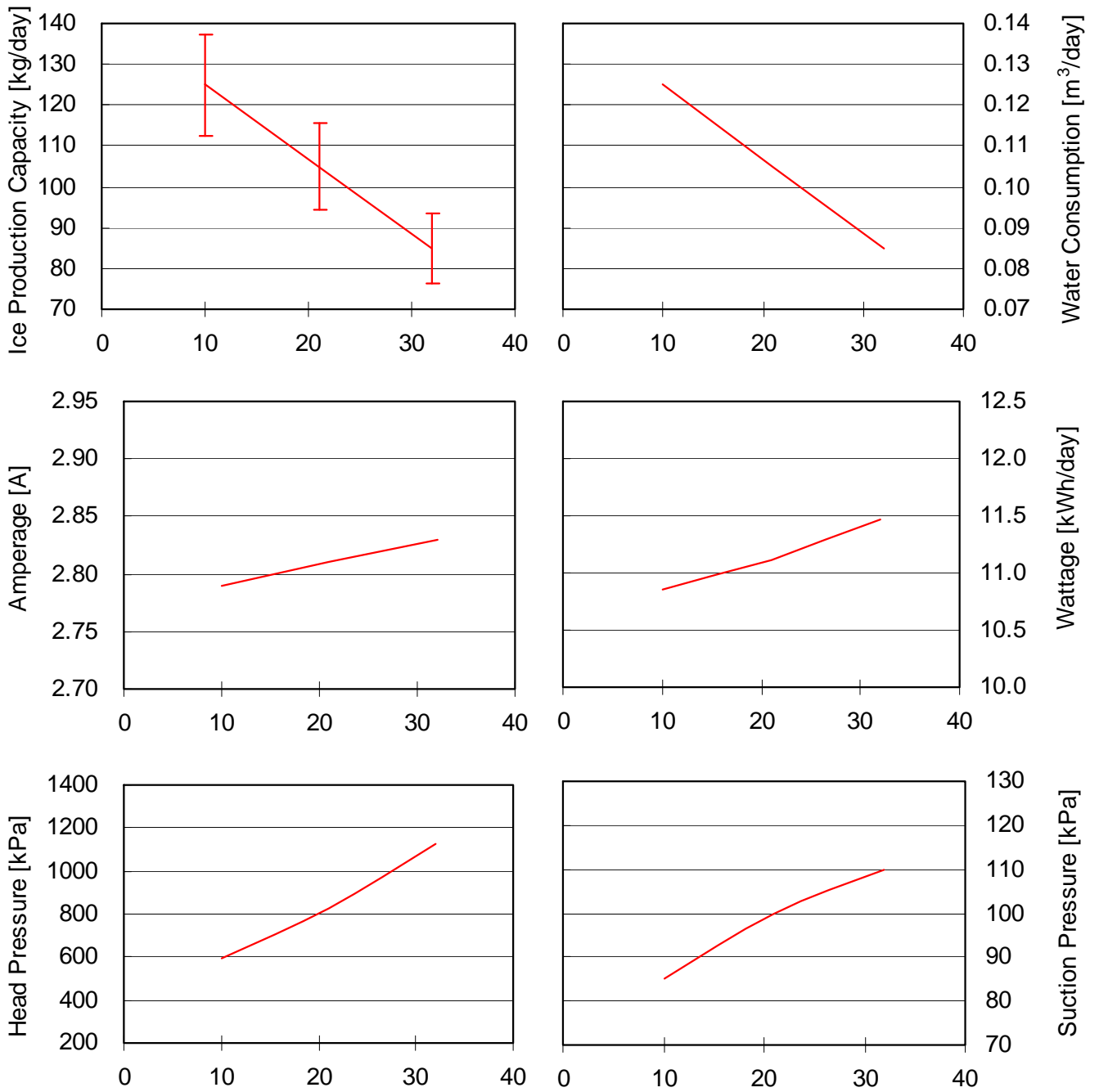

The horizontal axis shows the ambient temperature
 It refers to data of at/wt=10/10, 21/15, 32/21

[d] DCM-120KE(-P): 60Hz

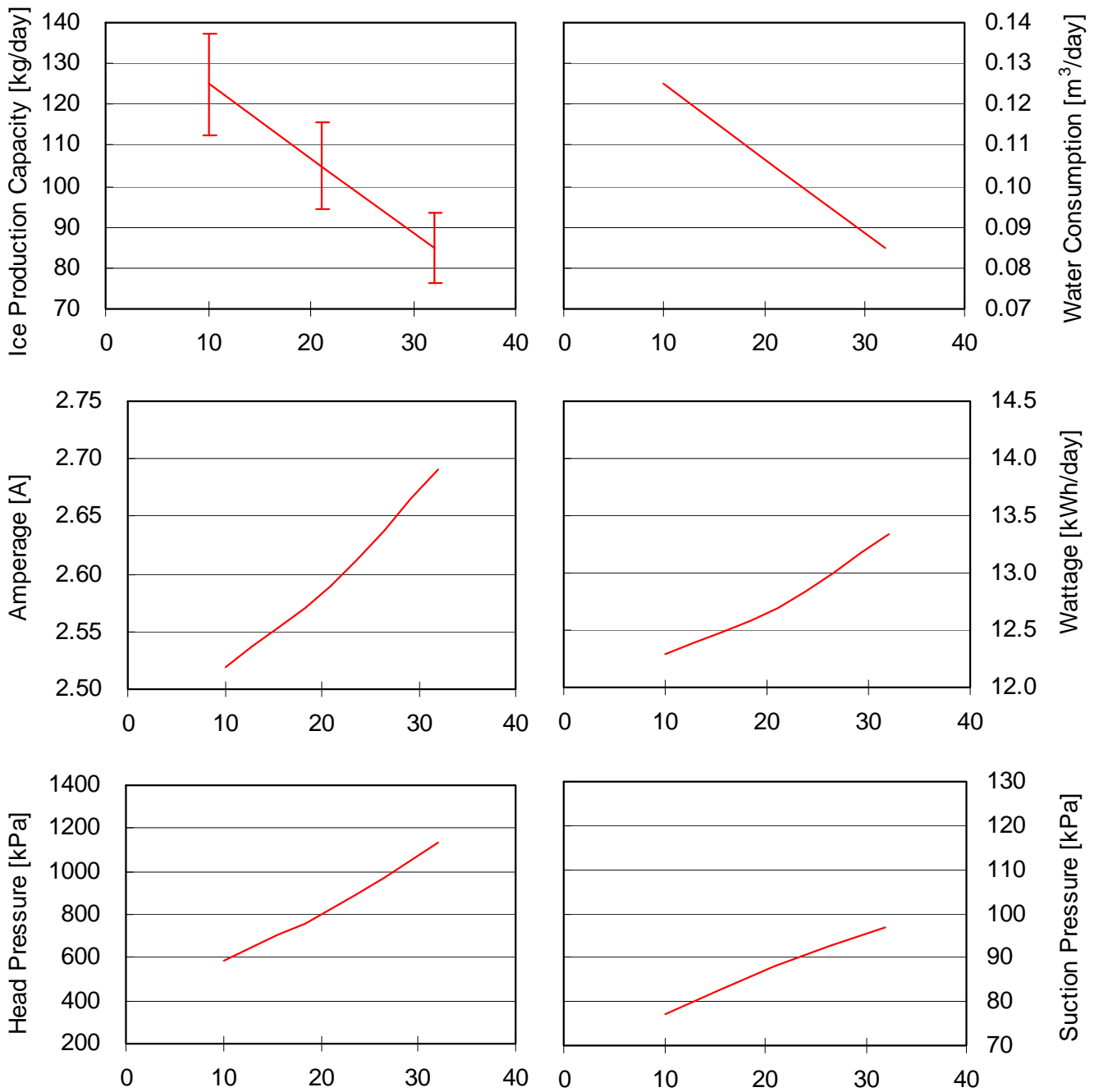

The horizontal axis shows the ambient temperature
 It refers to data of at/wt=10/10, 21/15, 32/21

8. ICE MAKING CAPACITY

[a] DCM-60KE(-P): 50/60Hz

Ambient temperature: 21°C

Water temperature: 15°C

Ice production: 50kg/day

Storage bin capacity: 1.9kg

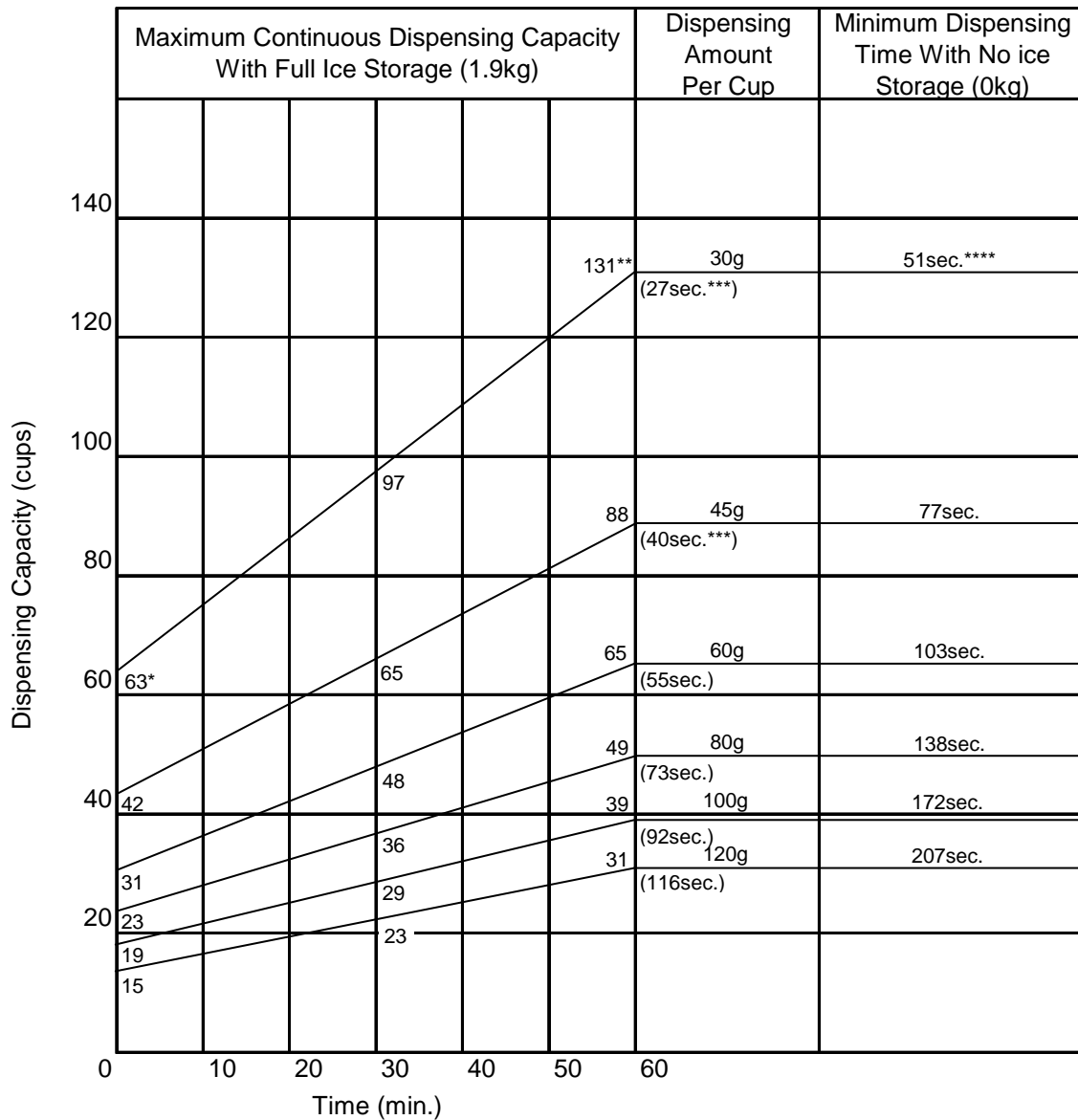

- * = Storage Capacity (1900g) / Dispensing Amount Per Cup (30g)
- ** = {Storage Capacity (1900g) + Ice Production Per Hour (2083g)} / Dispensing Amount Per Cup (30g)
- *** = 3600sec. (1Hour) / Dispensing Capacity (131cups)
- **** = Dispensing Amount Per Cup (30g) / Ice Production Per Second (0.58g)

[b] DCM-60KE(-P): 50/60Hz

Ambient temperature: 32°C
 Water temperature: 21°C

Ice production: 38kg/day
 Storage bin capacity: 1.9kg

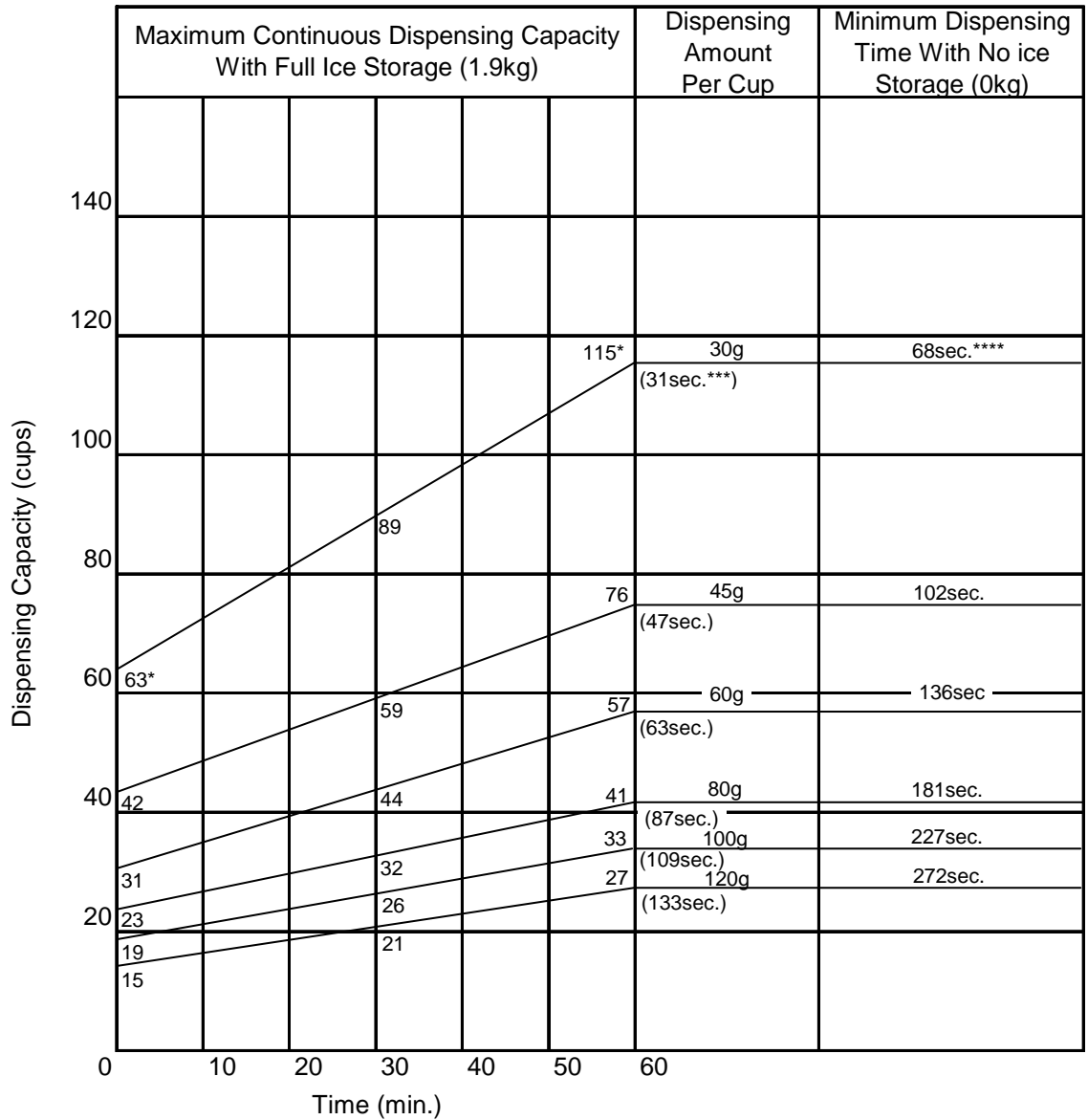

* = Storage Capacity (1900g) / Dispensing Amount Per Cup (30g)
 ** = {Storage Capacity (1900g) + Ice Production Per Hour (1583g)} / Dispensing Amount Per Cup (30g)
 *** = 3600sec. (1Hour) / Dispensing Capacity (115cups)
 **** = Dispensing Amount Per Cup (30g) / Ice Production Per Second (0.44g)

[c] DCM-120KE(-P): 50/60Hz

Ambient temperature: 21°C
 Water temperature: 15°C

Ice production: 105kg/day
 Storage bin capacity: 4kg

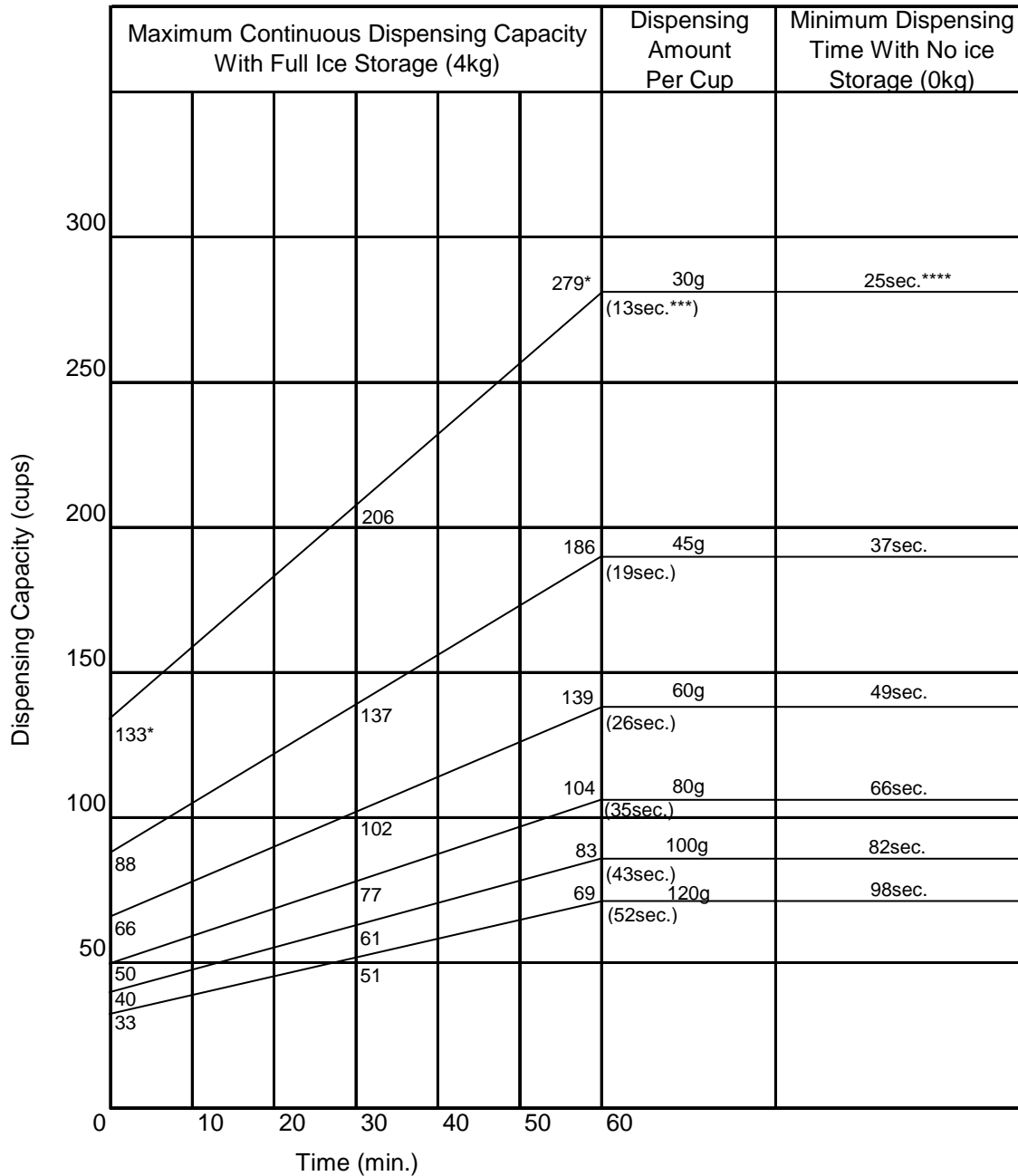

* = Storage Capacity (4000g) / Dispensing Amount Per Cup (30g)
 ** = {Storage Capacity (4000g) + Ice Production Per Hour (4375g)} / Dispensing Amount Per Cup (30g)
 *** = 3600sec. (1Hour) / Dispensing Capacity (279cups)
 **** = Dispensing Amount Per Cup (30g) / Ice Production Per Second (1.22g)

[d] DCM-120KE(-P): 50/60Hz

Ambient temperature: 32°C
 Water temperature: 21°C

Ice production: 85kg/day
 Storage bin capacity: 4kg

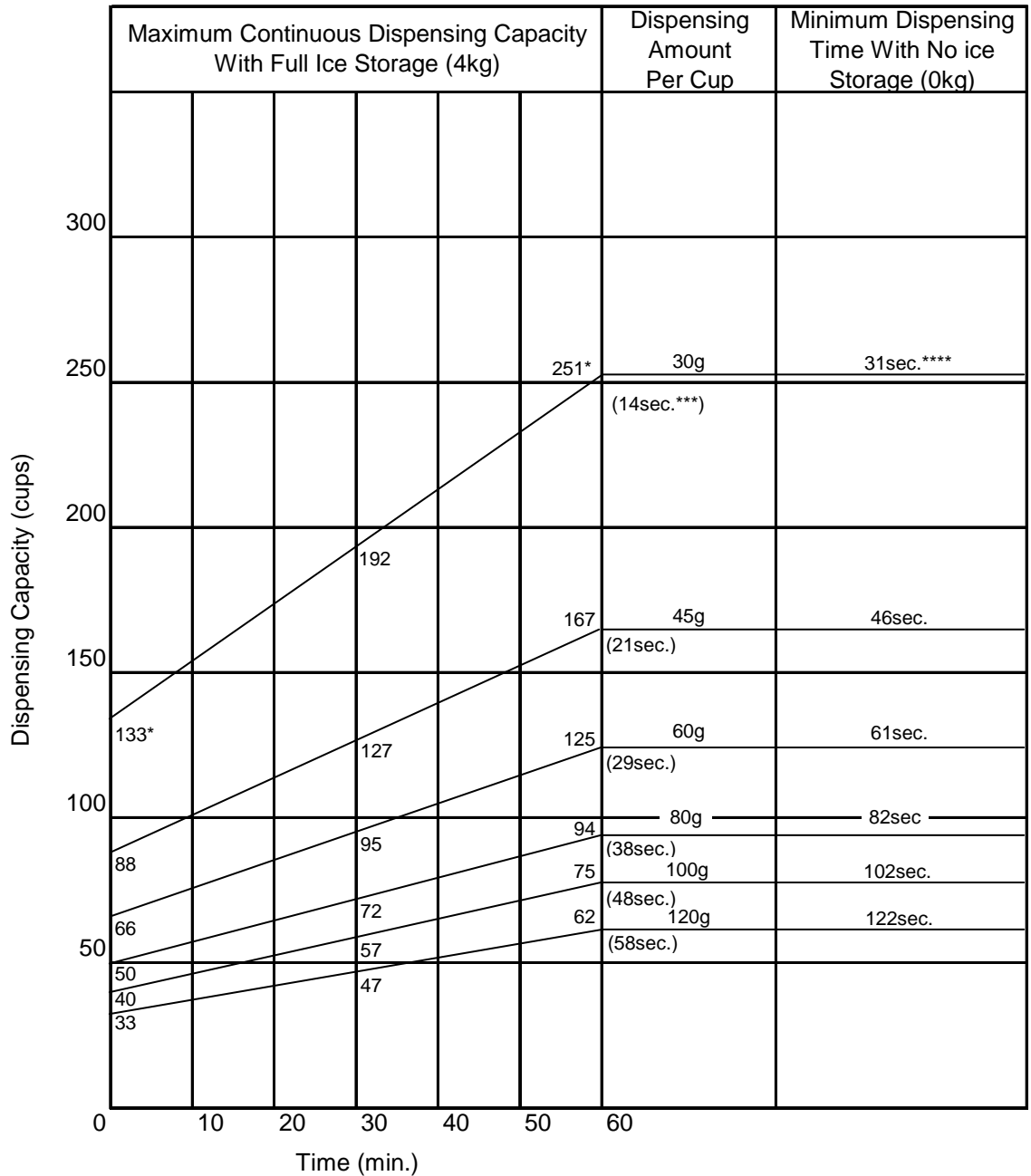

* = Storage Capacity (4000g) / Dispensing Amount Per Cup (30g)
 ** = {Storage Capacity (4000g) + Ice Production Per Hour (3542g)} / Dispensing Amount Per Cup (30g)
 *** = 3600sec. (1Hour) / Dispensing Capacity (251cups)
 **** = Dispensing Amount Per Cup (30g) / Ice Production Per Second (0.98g)

IV. SERVICE DIAGNOSIS

Display error records by operating the operation board (see “III. 5. [g] DISPLAYING ERROR LOG AND ONGOING ERROR”). Check for a possible cause and service the unit.

1. NO ICE PRODUCTION

PROBLEM	POSSIBLE CAUSE	REMEDY	
[1] The ice dispenser will not start.	a) Power supply	1. OFF position.	1. Move to ON position.
		2. Loose connections.	2. Tighten.
		3. Bad contacts.	3. Check for continuity and replace.
		4. Blown fuse.	4. Replace.
		5. Voltage too low.	5. Get recommended voltage.
	b) Fuse	1. Blown out. No indication on operation board.	1. Locate and resolve the cause of short circuit (ex. control water valve, flush water valve), and replace.
	c) Transformer receptacle	1. Disconnected.	1. Connect.
	d) Operation switch	1. OFF position.	1. Move to ON position.
		2. Bad contacts.	2. Check for continuity and replace.
	e) Transformer	1. Coil winding opened.	1. Replace.
	f) Water valve	1. Coil winding opened.	1. Replace.
	g) Water supply tap	1. Closed.	1. Open.
		2. Water failure.	2. Wait till water is supplied.
h) Plug and receptacle (control box)	1. Disconnected.	1. Connect.	
	2. Terminal out of plug or receptacle.	2. Insert terminal back in position.	
i) Overload protector	1. Tripped.	1. Reset.	
j) Model number	1. Incorrect.	1. Set correct number. See “III. 5. [d] SETTING MODEL NUMBER.	
[2] Water does not stop, and the ice dispenser will not start.	a) Water control relay (controller board)	1. Contacts fused.	1. Replace controller board.
		2. Coil winding opened.	2. Replace controller board.
	b) Float switch	1. Bad contacts.	1. Check for continuity and replace.
		2. Float does not move freely.	2. Clean or replace.
	c) Flush water valve	1. Valve seat clogged and water leaking.	1. Clean or replace.
	d) Hoses	1. Disconnected.	1. Connect.
	e) Mechanical seal	1. Water leaks.	1. Replace.
f) Reservoir	1. Cracked.	1. Replace.	
[3] Water has been supplied, but the ice dispenser will not start.	a) Bin control	1. Bad contacts.	1. Check for continuity and replace.
	b) Gear motor protector (thermal breaker)	1. Tripped.	1. Find out the cause, resolve it, and press reset button on motor protector.
	c) Controller board	1. Defective.	1. Replace.

PROBLEM	POSSIBLE CAUSE		REMEDY
[3] (Continued)	d) Condenser thermistor	1. Dirty condenser fins.	1. Clean.
		2. Ambient temperature too warm.	2. Check for recommended temperature.
		3. Fan not rotating.	3. Replace.
		4. Condenser water pressure too low or off.	4. Check and get recommended pressure.
		5. Water regulating valve clogged.	5. Clean.
		6. Refrigerant overcharged.	6. Recharge.
		7. Refrigerant line or components plugged.	7. Clean and replace drier.
		8. Bad contacts.	8. Check for continuity and replace.
		9. Loose connections.	9. Tighten.
	e) Gear motor protect relay	1. Coil winding opened.	1. Replace.
2. Bad contacts.		2. Check for continuity and replace.	
f) Capacitor	1. Defective	1. Replace.	
[4] Gear motor starts, but compressor will not start or operates intermittently.	a) Ice making switch	1. OFF position	1. Move to ON position.
	b) X3 relay (controller board)	1. Bad contacts.	1. Check for continuity and replace controller board.
		2. Coil winding opened.	2. Replace controller board.
	c) Compressor	1. Loose connections.	1. Tighten.
		2. Motor winding opened or earthed.	2. Replace.
		3. Motor protector tripped.	3. Find out the cause of overheat or overcurrent.
	d) Power supply	1. Circuit ampacity too low.	1. Install a larger-sized conductor.
	e) Controller board	1. Defective.	1. Replace.
f) Starter	1. Defective.	1. Replace.	
g) Start capacitor or run capacitor	1. Defective.	1. Replace.	
[5] Gear motor and compressor start, but no ice is produced.	a) Refrigerant line	1. Gas leaks.	1. Check for leaks with a leak detector. Reweld leak, replace drier and charge with refrigerant. The amount of refrigerant is marked on nameplate or label.
		2. Refrigerant line clogged.	2. Replace the clogged component.

2. LOW ICE PRODUCTION

PROBLEM	POSSIBLE CAUSE		REMEDY
[1] Low ice production	a) Refrigerant line	1. Gas leaks.	1. See 1 - [5] - a).
		2. Refrigerant line clogged.	2. Replace the clogged component.
		3. Overcharged.	3. Recharge.
	b) High-side pressure too high	1. Dirty air filter or condenser.	1. Clean.
		2. Ambient or condenser water temperature too warm.	2. Check for recommended temperature.
		3. Fan rotating too slow.	3. Replace.
		4. Bad ventilation.	4. Remove anything blocking vents.
		5. Less than 15 cm clearance at rear, sides and top.	5. Allow proper clearance for ventilation.
c) Expansion valve (not adjustable)	1. Low-side pressure exceeding the limit.	1. Replace.	
d) Evaporator	1. Evaporator pipe crushed.	1. Replace.	

3. FAULTY DISPENSER

PROBLEM	POSSIBLE CAUSE		REMEDY
[1] No ice is dispensed.	a) Storage bin	1. Ice block or bridge.	1. Remove all ice from storage bin when not using ice dispenser for a long time.
	b) Agitator	1. Deformed due to ice block or bridge.	1. Replace.
	c) Solenoid	1. Coil winding opened.	1. Replace.
	d) Lever switch	1. Bad contacts.	1. Check for continuity and replace.
[2] No water is dispensed.	a) Water valve (dispensing)	1. Clogged filter.	1. Clean.
		2. Coil winding opened.	2. Replace.
	b) Lever switch	1. Bad contacts.	1. Check for continuity and replace.
[3] Ice keeps being dispensed.	a) Shutter	1. Faulty adjustment.	1. With shutter closed, lock shutter in place by securing with two screws at the lower part of solenoid and two screws under solenoid.
	b) Lever switch	1. Contacts fused.	1. Replace.

4. OTHERS

PROBLEM	POSSIBLE CAUSE		REMEDY
[1] Abnormal noise	a) Fan motor (condenser unit)	1. Bearing worn out.	1. Replace.
		2. Fan blade deformed.	2. Replace fan blade.
		3. Fan blade does not move freely.	3. Replace.
	b) Compressor	1. Bearings worn out, or cylinder valve defective.	1. Replace.
		2. Mounting pad out of position.	2. Reinstall.
	c) Refrigerant lines	1. Rub or touch lines or other surfaces.	1. Replace.
d) Gear motor (ice making)	1. Bearing or gear wear/damage.	1. Replace.	
e) Evaporator	1. Low-side pressure too low.	1. See if expansion valve bulb is mounted properly, and replace the valve if necessary.	
	2. Scale on inside wall of freezing cylinder.	2. Remove auger. Use a solution of lime removing cleaner to clean periodically. If water is found to surpass the following levels, install a conditioner. Hardness 50 ppm Silica 30 ppm	
[2] Overflow from reservoir (Water does not stop.)	a) Water supply	1. Water pressure too high.	1. Install a pressure reducing valve.
	b) Water valve	1. Diaphragm does not close.	1. Clean or replace.
	c) Float switch	1. Bad contacts.	1. Check for continuity and replace.
[3] Gear motor protector operates frequently.	a) Power supply voltage	1. Too high or too low.	1. Connect the unit to a power supply of proper voltage.
	b) Evaporator assy	1. Bearings or auger worn out.	1. Replace bearing or auger.

V. REMOVAL AND REPLACEMENT

1. FRONT COVER

[a] REMOVAL

- 1) Remove the top panel.
- 2) Remove the two screws at the top of the front cover and the screw at the back of the ice spout.



- 3) Pull the top of the front cover forward.
(Hooks are provided at the bottom of the front cover.)

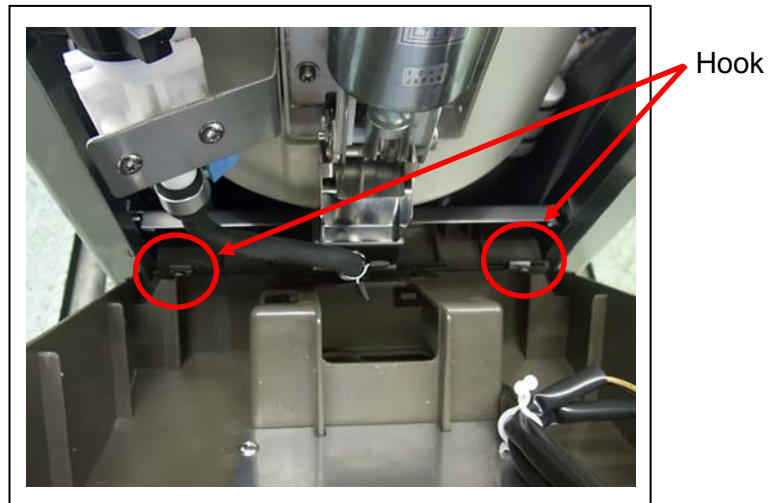

4) Disconnect the two connectors.



5) Lift off the front cover.



[b] REPLACEMENT

1) Replace the removed parts in the reverse order of which they were removed.

Note:

1. Before installing the front cover, put the water pipe through the front cover.



Water Pipe

2. Hook the bottom of the front cover as shown below, and push it in hard.

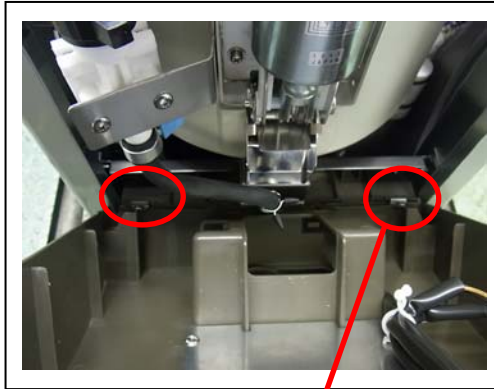

2. SERVICE FOR REFRIGERANT LINES

[a] SERVICE INFORMATION

1) Allowable Compressor Opening Time and Prevention of Lubricant Mixture [R134A]

The compressor must not be opened more than 15 minutes in replacement or service. Do not mix lubricants of different compressors even if both are charged with the same refrigerant, except when they use the same lubricant.

2) Treatment for Refrigerant Leak [R134A]

If a refrigerant leak occurs in the low side of an ice dispenser, air may be drawn in. Even if the low side pressure is higher than the atmospheric pressure in normal operation, a continuous refrigerant leak will eventually lower the low side pressure below the atmospheric pressure and will cause air suction. Air contains a large amount of moisture, and ester oil easily absorbs a lot of moisture. If an ice dispenser charged with R134A has possibly drawn in air, the drier must be replaced. Be sure to use a drier designed for R134A.

3) Handling of Handy Flux [R134A]

Repair of the refrigerant circuit requires brazing. It is no problem to use the same handy flux that has been used for the current refrigerants. However, its entrance into the refrigerant circuit should be avoided as much as possible.

4) Oil for Processing of Copper Tubing [R134A]

When processing the copper tubing for service, wipe off oil, if any used, by using alcohol or the like. Do not use too much oil or let it into the tubing, as wax contained in the oil will clog the capillary tubing.

5) Service Parts for R134A

Some parts used for refrigerants other than R134A are similar to those for R134A. But never use any parts unless they are specified for R134A because their endurance against the refrigerant has not been evaluated. Also, for R134A, do not use any parts that have been used for other refrigerants. Otherwise, wax and chlorine remaining on the parts may adversely affect R134A.

6) Replacement Copper Tubing [R134A]

The copper tubes currently in use are suitable for R134A. But do not use them if oily inside. The residual oil in copper tubes should be as little as possible. (Low residual oil type copper tubes are used in the shipped units.)

7) Evacuation, Vacuum Pump and Refrigerant Charge [R134A]

Never allow the oil in the vacuum pump to flow backward. The vacuum level and vacuum pump may be the same as those for the current refrigerants. However, the rubber hose and gauge manifold to be used for evacuation and refrigerant charge should be exclusively for R134A.

8) Refrigerant Leak Check

Refrigerant leaks can be detected by charging the unit with a little refrigerant, raising the pressure with nitrogen and using an electronic detector. Do not use air or oxygen instead of nitrogen for this purpose, or rise in pressure as well as in temperature may cause R134A to suddenly react with oxygen and explode. Be sure to use nitrogen to prevent explosion.

[b] REFRIGERANT RECOVERY

The refrigerant must be recovered if required by an applicable law. Recover the refrigerant from the access valve, and store it in a proper container. Do not discharge the refrigerant into the atmosphere.

When replacing the drier, take the opportunity to also fit a low-side access valve and a high-side access valve for ease of charging liquid refrigerant.

[c] EVACUATION AND RECHARGE

- 1) Attach a charging hose of a gauge manifold to a vacuum pump and the low-side access valve (to be fitted by service personnel).
- 2) Open the low-side valve on the gauge manifold, and turn on the vacuum pump.
- 3) Allow the vacuum pump to pull down to a 760 mmHg vacuum. Evacuating period depends on the pump capacity.
- 4) Close the low-side valve on the gauge manifold.
- 5) Disconnect the vacuum pump, and attach a refrigerant charging cylinder to accurately weigh in the liquid charge. Remember to purge any air from the charging hose. See the nameplate for the required refrigerant charge.
- 6) Open the low-side valve on the gauge manifold and the valve on the charging cylinder.
- 7) When no more refrigerant is drawn in, turn on the ice dispenser. When the required amount of refrigerant has been charged, close the valve on the charging cylinder and turn off the ice dispenser.
- 8) Close the low-side valve on the gauge manifold.
- 9) Disconnect the charging hose from the access valve. Always cap the access valve to prevent a refrigerant leak.
- 10) Always thoroughly leak test all joints and valve caps.
- 11) Avoid charging large quantities of liquid into the low side in case of damage to the compressor.

3. BRAZING

DANGER

1. Refrigerant R134A itself is not flammable, explosive and poisonous. However, when exposed to an open flame, R134A creates phosgene gas, hazardous in large amounts.
2. Always recover the refrigerant and store it in a proper container, if required by an applicable law. Do not discharge the refrigerant into the atmosphere.
3. Do not use silver alloy or copper alloy containing arsenic.
4. In its liquid state, the refrigerant can cause frostbite because of the low temperature.

4. COMPRESSOR

IMPORTANT

Always install a new drier every time the sealed refrigeration system is opened. Do not replace the drier until after all other repair or replacement has been made.

- 1) Unplug the ice dispenser.
- 2) Remove the panels.
- 3) Remove the terminal cover on the compressor, and disconnect the compressor wiring.
- 4) Recover the refrigerant and store it in a proper container, if required by an applicable law (See "2. [b] REFRIGERANT RECOVERY").
- 5) Remove the discharge, suction and access pipes from the compressor using brazing equipment.

WARNING

When repairing a refrigerant system, be careful not to let the burner flame contact any electrical wires or insulation.

- 6) Remove the bolts and rubber grommets.
- 7) Slide and remove the compressor. Unpack the new compressor package. Install the new compressor.
- 8) Attach the rubber grommets of the previous compressor.
- 9) Clean the suction and discharge pipes with an abrasive cloth/paper.

- 10) Place the compressor in position, and secure it using the bolts and washers.
- 11) Remove plugs from the discharge, suction and access pipes.
- 12) Braze the access, suction and discharge pipes (Do not change this order) with nitrogen gas flowing at the pressure of 0.2 - 0.3 bar.
- 13) Install the new drier (See "5. DRIER").
- 14) Check for leaks using nitrogen gas (10 bar) and soap bubbles.
- 15) Evacuate the system, and charge it with refrigerant. See the nameplate for the required refrigerant charge (See "2. [c] EVACUATION AND RECHARGE").
- 16) Connect the terminals to the compressor, and replace the terminal cover in its correct position.
- 17) Refit the panels in their correct position.
- 18) Plug in the ice dispenser.

5. DRIER

IMPORTANT

Always install a new drier every time the sealed refrigeration system is opened. Do not replace the drier until after all other repair or replacement has been made.

- 1) Unplug the ice dispenser.
- 2) Remove the front cover.
- 3) Recover the refrigerant and store it in a proper container, if required by an applicable law (See "2. [b] REFRIGERANT RECOVERY").
- 4) Remove the drier using brazing equipment.
- 5) Install the new drier with the arrow on the drier in the direction of the refrigerant flow. Use nitrogen gas at the pressure of 0.2 - 0.3 bar when brazing the tubings.
- 6) Check for leaks using nitrogen gas (10 bar) and soap bubbles.
- 7) Evacuate the system, and charge it with refrigerant. See the nameplate for the required refrigerant charge (See "2. [c] EVACUATION AND RECHARGE").
- 8) Refit the front cover in its correct position.
- 9) Plug in the ice dispenser.

6. EXPANSION VALVE

IMPORTANT

Sometimes moisture in the refrigerant circuit exceeds the drier capacity and freezes up at the expansion valve. Always install a new drier every time the sealed refrigeration system is opened. Do not replace the drier until after all other repair or replacement has been made.

- 1) Unplug the ice dispenser.
- 2) Remove the front cover.
- 3) Recover the refrigerant and store it in a proper container, if required by an applicable law (See "2. [b] REFRIGERANT RECOVERY").
- 4) Remove the expansion valve bulb at the evaporator outlet.
- 5) Remove the expansion valve cover, and disconnect the expansion valve using brazing equipment.
- 6) Braze the new expansion valve with nitrogen gas flowing at the pressure of 0.2 - 0.3 bar.

WARNING

Always protect the valve body by using a damp cloth to prevent the valve from overheating. Do not braze with the valve body exceeding 120°C.

- 7) Install the new drier (See "5. DRIER").
- 8) Check for leaks using nitrogen gas (10 bar) and soap bubbles.
- 9) Evacuate the system, and charge it with refrigerant. See the nameplate for the required refrigerant charge (See "2. [c] EVACUATION AND RECHARGE").
- 10) Attach the bulb to the suction line. Be sure to secure the bulb using a wire or clamp and replace the insulation.
- 11) Place the new set of expansion valve covers in position.
- 12) Refit the front cover in its correct position.
- 13) Plug in the ice dispenser.

7. FAN MOTOR

- 1) Unplug the ice dispenser.
- 2) Remove the cabinet.
- 3) Disconnect the lead wires at their connection.
- 4) Take out the fan motor with its bracket from the unit.

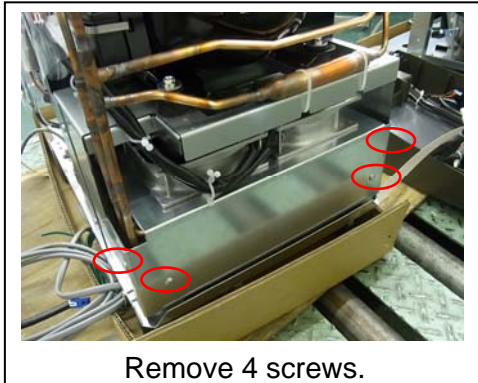

- 5) Remove the fan motor from the fan motor bracket.
- 6) Assemble the removed parts in the reverse order of which they were removed.

8. EVAPORATOR ASSEMBLY

See the exploded view under “III. 3. ICEMAKING MECHANISM”.

- 1) Move the ice making switch to the “OFF” position.
- 2) Press the push lever or dispense switch to dispense ice, and remove all ice from the storage bin.
- 3) Press the drain switch on the control panel. The display illuminates “DRAIN” during the 1 minute drain cycle.
- 4) Unplug the ice dispenser.
- 5) Remove the panels.
- 6) Remove the storage bin assembly (See “13. STORAGE BIN ASSEMBLY”).

EXTRUDING HEAD

- 7) Remove the sealing bolts, and lift off the extruding head.
- 8) Check the bearing inside the extruding head. If it is worn out or scratched, replace the bearing.

Note: Replacing the bearing needs a fitting tool. If it is not available, replace the whole extruding head.

AUGER

- 9) Lift out the auger. Check the top and bottom areas in contact with the bearings. If the surface is scratched or pitted, replace the auger. Check the blade edge of the auger. If it is scratched or worn where it has contacted the evaporator, replace it.

EVAPORATOR

Note: Skip the following steps 10) through 15) when the evaporator does not need replacement.

- 10) Recover the refrigerant and store it in a proper container, if required by an applicable law (See "2. [b] REFRIGERANT RECOVERY").

IMPORTANT

Always install a new drier every time the sealed refrigeration system is opened. Do not replace the drier until after all other repair or replacement has been made.

- 11) Remove the bulb of the expansion valve.
- 12) Disconnect the brazing connections of the expansion valve and the copper tube - low side from the evaporator, using brazing equipment.

WARNING

Always protect the valve body by using a damp cloth to prevent the valve from overheating. Do not braze with the valve body exceeding 120°C.

- 13) Disconnect the hoses from the evaporator.
- 14) Remove the four socket head cap screws securing the evaporator with the housing.
- 15) Lift off the evaporator.

HOUSING AND MECHANICAL SEAL

- 16) The mechanical seal consists of two parts. One part rotates with the auger, the other is static and is fitted into a top recess in the housing. If the contact surfaces of these two parts become worn or scratched, the mechanical seal may leak water and should be replaced.
- 17) Remove the O-ring on the top outer edge of the housing.

- 18) Remove the four bolts and lift the housing clear of the gear motor. Check the bearing inside the housing. If it is worn or scratched, replace it using a fitting tool. Carefully ease out the lower part of the mechanical seal before replacing the bearing.

Note: If a fitting tool is not available, replace the whole lower housing complete with bearing.

GEAR MOTOR

- 19) Cut the connectors.
- 20) Remove the three socket head cap screws securing the gear motor.
- 21) Assemble the removed parts in the reverse order of which they were removed.

WARNING

Be careful not to scratch the surface of the O-ring, or it may cause water leaks. Handle the mechanical seal with care not to scratch nor to contaminate its contact surface.

- 22) When replacing the evaporator:
 - (a) Braze the new evaporator with nitrogen gas flowing at the pressure of 0.2 - 0.3 bar.
 - (b) Replace the drier.
 - (c) Check for leaks using nitrogen gas (10 bar) and soap bubbles.
 - (d) Evacuate the system, and charge it with refrigerant. See the nameplate for the required refrigerant charge (See "2. [c] EVACUATION AND RECHARGE").
- 23) Refit the panels in their correct position.
- 24) Plug in the ice dispenser.

9. CONTROL WATER VALVE AND WATER DISPENSE VALVE

- 1) Unplug the ice dispenser.
- 2) Close the water supply tap.
- 3) Remove the panels.
- 4) Disconnect the terminals from the valve.
- 5) Loosen the fitting nut on the valve inlet, and remove the valve. Do not lose the packing inside the fitting nut.

- 6) Install the new valve.
- 7) Assemble the removed parts in the reverse order of which they were removed.
- 8) Open the water supply tap.
- 9) Plug in the ice dispenser.
- 10) Check for water leaks.
- 11) Refit the panels in their correct position.

10. FLUSH WATER VALVE

- 1) Move the ice making switch to the “OFF” position.
- 2) Press the drain switch on the control panel. The display illuminates “DRAIN” during the 1 minute drain cycle.
- 3) Unplug the ice dispenser, and close the water supply tap.
- 4) Remove the panels.
- 5) Remove the clamp and disconnect the hose from the flush water valve.

Note: Water may still remain inside the evaporator. Be sure to drain the water into the drain pan.

- 6) Disconnect the terminals from the flush water valve.
- 7) Remove the flush water valve from the bracket.
- 8) Remove the drain pipe from the flush water valve.
- 9) Connect the drain pipe to the new flush water valve, and place the valve in position.
- 10) Connect the hose to the flush water valve, and secure it with the clamp.
- 11) Pour water into the reservoir, and check for water leaks on the flush water valve.
- 12) Open the water supply tap.
- 13) Plug in the ice dispenser.
- 14) Check for water leaks.
- 15) Push the drain switch, and make sure water is flushing.
- 16) Refit the panels in their correct position.

11. CONTROLLER BOARD

IMPORTANT

A single type controller board is supplied as a service board. Some modifications and adjustment will be required to fit the ice dispenser models. Do not repair any parts and electronic devices on the controller board in the field. Replace the whole board with a new service board.

[a] MODIFICATION

- 1) Check that the service board package includes:
Controller board 1 pc. Instruction sheet 1 pc.
- 2) Modify the service board referring to the instruction sheet attached (Set the model number according to "III. 5. [d] SETTING MODEL NUMBER").

[b] REPLACEMENT

- 1) Unplug the ice dispenser.
- 2) Remove the panels.
- 3) Remove the control box.
- 4) Disconnect the connectors and board support from the controller board.
- 5) Remove the controller board from the control box.
- 6) Install the new controller board and reassemble the control box in the reverse order of the removal procedure.
- 7) Replace the panels in their correct position.
- 8) Plug in the ice dispenser.

12. BIN CONTROL SWITCH ASSEMBLY

- 1) Unplug the ice dispenser.
- 2) Remove the top panel.
- 3) Remove the storage bin cover.
- 4) Remove the bin control switch.
- 5) Remove the snap pin and E-ring, and disassemble the balance plate (B) and shaft.
- 6) Install the new bin control switch assembly.
- 7) Assemble the removed parts in the reverse order of which they were removed.
- 8) Plug in the ice dispenser, and check that the bin control switch works normally.

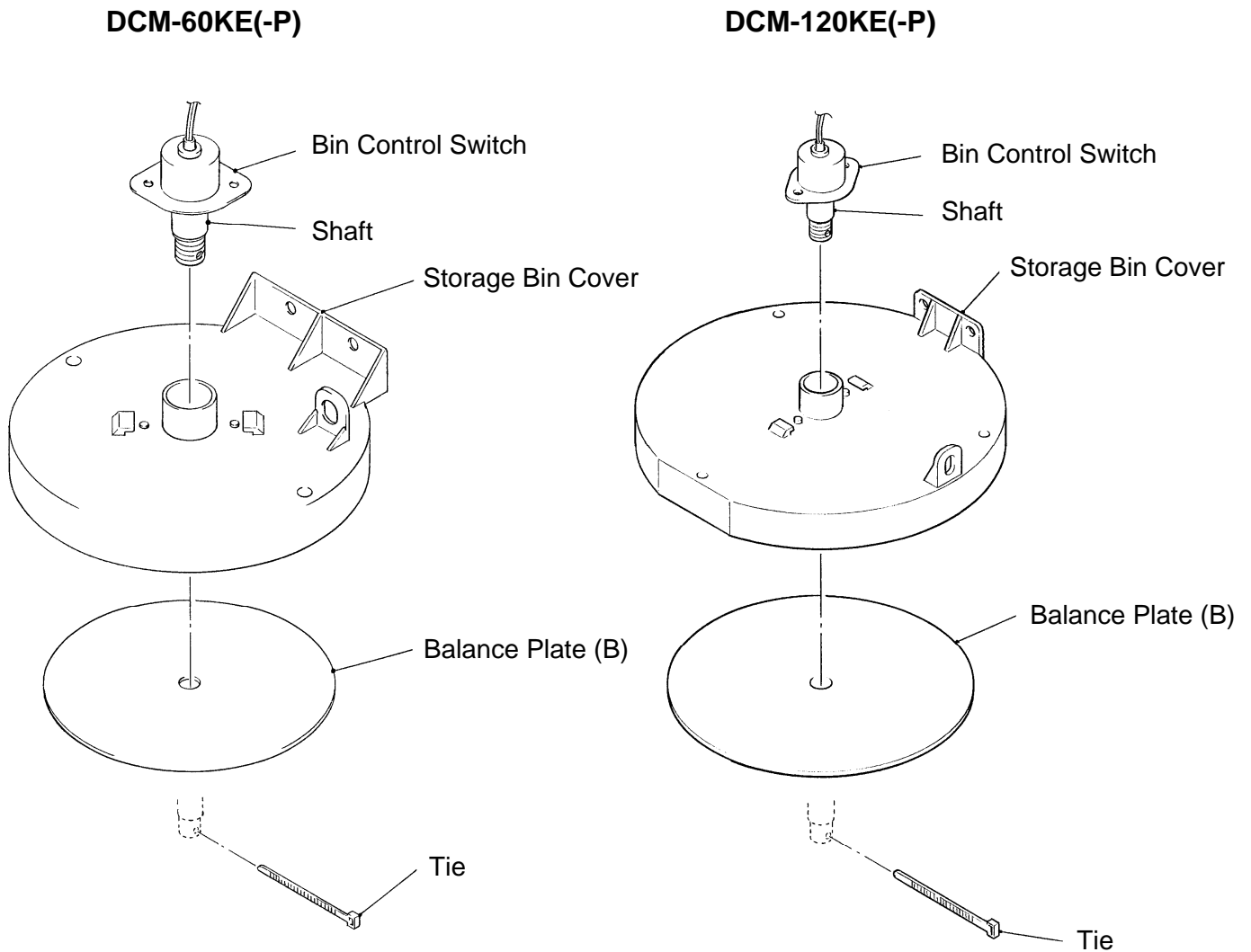

13. STORAGE BIN ASSEMBLY

- 1) Move the ice making switch to the "OFF" position.
- 2) Press the push lever or dispense switch to dispense ice, and remove all ice from the storage bin.
- 3) Press the drain switch on the control panel. The display illuminates "DRAIN" during the 1 minute drain cycle.
- 4) Unplug the ice dispenser.
- 5) Remove the panels.
- 6) Remove the storage bin cover.
- 7) Remove the agitator, drip ring and shutter assembly.
- 8) Remove the three sealing bolts, and lift off the storage bin assembly.
- 9) Install the new storage bin assembly.
- 10) Assemble the removed parts in the reverse order of which they were removed.
- 11) Plug in the ice dispenser.
- 12) Mover the shutter to check for proper operation.

14. AGITATOR AND DRIP RING

- 1) Move the ice making switch to the "OFF" position.
- 2) Press the push lever or dispense switch to dispense ice, and remove all ice from the storage bin.
- 3) Unplug the ice dispenser.
- 4) Remove the top panel.
- 5) Remove the storage bin cover.
- 6) Rotate the agitator counterclockwise, and lift off.
- 7) Rotate the dip ring about 30 degrees clockwise, and lift out.
- 8) Install the new drip ring and agitator.
- 9) Assemble the removed parts in the reverse order of they were removed.
- 10) Plug in the ice dispenser.