



Client _____ Quantity _____

Project _____ Position _____

FUN 700

Model: F70/40BME/A

Cod: MP01252123001

Technical data

Modularity:	On open cabinet
Dimension (mm):	400x700x850
Total electric power (kW):	1,5
Nr. Wells:	1
Well litres 1:	16
Well dimensions 1 (mm):	305x510x155
Electric power (V):	220-240
Ampere (A):	7
Phases:	1
Cable section (mmq):	3G1,5
Frequency (Hz):	50-60
Drain size:	1/2"
Net volume (m3):	0,238
Packing dimensions (mm):	477x776x1147
Gross weight (kg):	37
Gross volume (m3):	0,425

Features

Working top:	Made of AISI 304 stainless steel with a thickness of 10/10 mm
Knobs:	Knobs are made from a sturdy heat-resistant polymer blend and are equipped with liquid anti-leakage washer
Water inflow:	Manual input

Technical draw

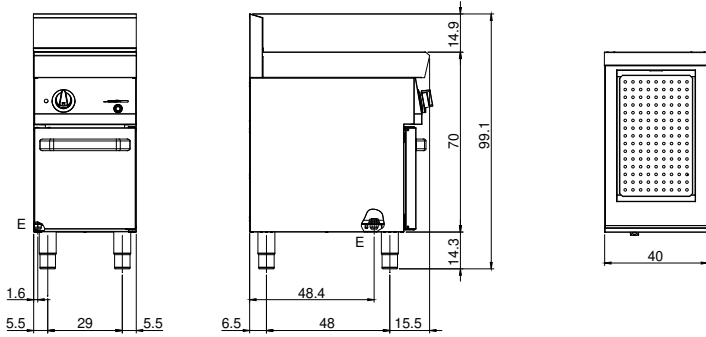

E: Electric power