



Client _____ Quantity _____
Project _____ Position _____

FUN 700

Model: F70/40CPE/1V40/P

Cod: MP01212123000

Technical data

Modularity:	On cabinet with door
Dimension (mm):	400x700x850
Total electric power (kW):	7,6
Nr. Wells:	1
Well litres 1:	40
Well dimensions 1 (mm):	306x508x296
Electric power (V):	380-415
Ampere (A):	12
Phases:	3N
Cable section (mmq):	5G1,5
Frequency (Hz):	50-60
Cold water inflow:	1/2"
Cold water pressure (bar):	Pressione Max 5 bar
Drain size:	1"
Net volume (m3):	0,238
Packing dimensions (mm):	477x776x1147
Gross weight (kg):	43
Gross volume (m3):	0,425

Features

Working top:	Made of AISI 304 stainless steel with a thickness of 10/10 mm
Knobs:	Knobs are made from a sturdy heat-resistant polymer blend and are equipped with liquid anti-leakage washer
Water inflow:	With tap

Technical draw

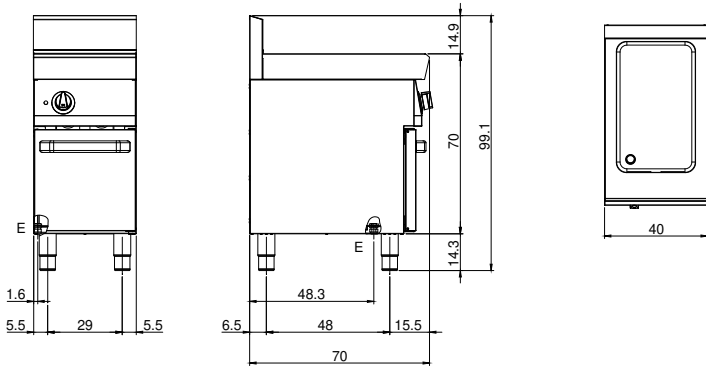

E: Electric power

D: Drain for water

H2O: Water inflow 3/4"